



# NATIONAL AUTOGRASS SPORT ASSOCIATION LTD.

NASA --- SCRUTINEERS COMMITTEE MEETING

REF: S3MIN0613/DH/GIJ

SATURDAY, 22nd JUNE 2013 - 12 NOON

TRAVELODGE WALSALL.

Present

C. SCRUTINEERS	No.	LEAGUE	SCRUTINEERS CLUB
Y	16	CGTRO(LINCOLN)	CGTRO
*	25	C. SCOTLAND	EA
Y	14	EAST ANGLIA	Glos
Y	01	EAST MIDLANDS	Southern
Y	11	ESSEX	Nott
*	24	FENLAND	
Y	02	GLOUCESTER	
*	18	KENT	
Y	07	MIDLAND AP	
*	09	NORTH WESTERN	
*	21	NORTHERN IRELAND	
*	10	NORTH YORKSHIRE	
*	15	SHROPSHIRE AA	
*	04	SOUTH WALES	
*	19	THE DALES	
Y	05	SOUTHERN	
*	23	IRELAND	
*	03	WESTERN ASA	
*	13	WEST WALES	
*	06	WEST MIDLANDS	
*	22	WILTSHIRE	
*	12	YORKSHIRE	

NASA Chief Scrutineer/Director

APOLOGIES: Scrut Sec. EA, NW, WW League Chief Scrutineers. CL 2 TL.

Scrutineers marked + are Club scrutineers representing League in place of League Chief Scrutineer.

VISITORS:

**ASSOCIATION OF  
AUTHORISING  
BODIES**

Office: 53 Andrew Drive, Haywood Oaks, Blidworth, Notts. NG21 0TX  
Registered in England and Wales -- Company No. 1716574



**Note.**

*The minutes have been compiled by Scrutineers Secretary based upon notes taken at the meeting by others.*

**1. INTRODUCTION.**

NASA Chief Scrutineer welcomed those present, and thanked them for attending.

**2. MINUTES OF PREVIOUS MEETING - 13/04/13 and MATTERS ARISING:**

**Page 1 – Noise meter.**

NASA Specials TL enquires as to the situation regarding noise meter for NASA Noise Tester.

NASA Chief Scrutineer explained that he had enquired at Board and had been informed that the noise meter had been given to the Noise Tester.

NASA Specials TL commented that this was not the case. The noise meter had definitely not been given to the noise tester.

NASA Chief Scrutineer would pursue the matter.

**Page 1. – Availability of 2014 rules.**

CGTRO Rep. enquired as to the current situation regarding 2014 rule changes being available online during August 2013.

NASA Chief Scrutineer explained that this was still being discussed at Board. The 2014 changes had been ratified. See end of minutes.

Unless there was an urgent safety issue encountered before the end of the season there would be no other changes for 2014.

*Note. If proceeded with, any rules information “Online” will not be a substitute for the rule book. A rule book and Licence will still require purchasing for the race season concerned. In the event of any conflict in wording the rule book will apply.*

**Page 1. – Roll Cage – Head Clearance.**

NASA Chief Scrutineer explained that the 75mm (3”) clearance is from the underside of the main roll bar hoops and roof bars.

He requested that monitoring is continued as a clarification amendment may be required in near future due to the ‘Lower’ roofs of some modern cars.

**Page 5. – Class survey results – See later in meeting.**

**Page 5. – Class 4, 5, 6, 7. - Bulkhead requirements**

CGTRO Rep. commented that he had checked approx 20 cars and only 2 were found not to comply.

There were no other matters arising.

PROPOSED: CGTRO Rep.

SECONDED: EA Rep.

That the minutes be accepted as a true record.

**UNANIMOUS**

**CARRIED**

**3. CORRESPONDENCE:**

- 1. East Anglia League – 3 items.
- 1. Aluminium race seats – use of cushions or similar to support and hold driver in seat. Some of these items are not fixed and come loose, sag or compress and collapse and or cause loosening of harness and submarining through harness.

Brief discussion followed including reference to need for such items to be fit for purpose. Rules already state that any ‘Padding’ used must be securely fixed.

2. Suggest use of “VIN number” or formal chassis identification to assist in clarifying original constructor.

Brief discussion followed including reference to original chassis may have been constructed to be fully compliant with rules for particular class it was to be raced in, but when ‘Sold on’ subsequent owners may have modified chassis to suit alternative class and also make it non compliant. Some chassis constructors are aware of this; however it is outside of their control. Use of “VIN number” etc would not prevent this.

3. Micra – Panhard rod – Use of polybushes.  
The cost of obtaining a replacement rod via a Nissan dealer is very expensive and seemingly difficult to obtain. When sourcing replacement rod from scrapped vehicles the standard bush often needs to be destroyed to remove rod.  
Can replacement polybushes be used as this would assist in obtaining a ‘used rod’ and new bushes at a low cost.

NASA Chief Scrutineer explained there was no objection to this.

There was no other correspondence received.

#### **4. VEHICLE CONSTRUCTION RULES & REGULATIONS.**

##### **a. Class 1 & 2**

- i. Experimental vehicles / Trials.

NASA Chief Scrutineer explained that the situation remained as that at the previous meeting.

YARIS – Head thickness details still required and awaited.

YARIS – Ride height details still required and awaited.

##### **b. Tyres – Update.**

The Tyre Co-ordinator explained that nothing had changed since last meeting.

NASA Chief Scrutineer explained that there were still concerns regarding unavailability of some tyres in 10” form.

##### **c. Chief Scrutineers Report.**

NASA Chief Scrutineer explained that the scrutineering in general had not thrown up any major issues. Some items were being missed. Missing and or incorrect/non-compliant identification on vehicles was still an issue.

##### Wheels- Lightening of.

NASA Chief Scrutineer explained that a Formula 600 vehicle had been found at a Leewood club meeting with lightened wheels in that the main spokes had been drilled with large diameter cutter to remove metal. This weakens the wheel substantially, renders the wheel as ‘damaged’ and is regarded as potentially dangerous for motorsport use and thus prohibited.

Rules 2.2, 2.5, and 24.2 applied in this case

However when a scrutineer had attempted to stop the use of the wheels concerned and confiscate them the answer allegedly given was that the F600 committee allowed it and NASA scrutineers were overruled by this and could not stop the wheels being used.

NASA Chief Scrutineer explained that this was not the case. NASA scrutineers had overall control of all vehicles that raced in Autograss. The F600 cars are deemed as Class 8 vehicles and hence are definitely under the overall control of the NASA Vehicle Construction Rules and the situation covered by Rules 2.2, 2.5, and 24.2

The Board had discussed this situation and a letter had been sent to the competitor concerned confirming that the rules quoted above applied and that the NASA Chief Scrutineer is the judge of fact in respect of compliance with the vehicle construction rules and the items concerned were non-compliant. Further or continued non-compliance could result in disciplinary action as per the NASA Members Handbook.

Also that it be understood that the F600 drivers committee and other similar bodies have no authority to overrule any club, league or NASA appointed scrutineer.

A copy of the letter has also been sent to the F600 committee.

Picture of wheel concerned



Brief discussion followed including reference to. Other short circuit motorsports permit this, however they race on sealed surface and wheels are not subject to same stresses as Autograss. There may have been an alleged personality clash during competitor & club scrutineer discussions.

NASA Chief Scrutineer hoped that the above clarified the situation for future reference.

Rules online.

NASA Chief Scrutineer explained that the Board had discussed this and a "Information Sheet" version of the rules were currently being sorted by Scrutineers Secretary and NASA Director JP.

*Note. Any rules information "Online" will not be a substitute for the rule book. A rule book and Licence will still require purchasing. In the event of any conflict in wording the rule book will apply.*

#### **d. Feedback from Leagues regarding Class Changes Survey.**

NASA Chief Scrutineer enquired if there was any feedback.

Some leagues had not fully discussed issue yet.

Class 4

In general terms those League representatives present felt that the RWD vehicles would die out naturally as there were very few racing. Did not feel need at present to specifically ban them by any rule amendments at this time.

## **National Autograss Championships 2013**

### **Scrutineers.**

A letter is sent in April/May to each League Chief Scrutineer requesting names, for duties at the NAC's.

Some Leagues have already replied - Any more??

Only 7 Leagues in total had bothered to reply out of 22. This was a very poor response.

For allocation list - See page 12. *Note. Volunteer scrutineers will be given gate refund and award for "Working" at NAC's.*

### Gasket Costs increased for 2013.

The gasket costs will only be paid for vehicles stripped on the day on the field.

Up to a maximum of : Class 1 & 2 £50, Class 3 - 10 £50.

Oil allowance of: All Classes - £20.

Bay 1 - Host league to supply 6 persons for brake/safety checks.

Bay 2 – Host league to supply 10 no "Signing on" persons – 1 per class.

General discussion followed on duties and workload at nationals.

See Scrutineering times guide in reminders section at end of minutes.

### **"Men's" Nationals.**

No representative from Wiltshire League present to provide specific update of situation.

"Brake testing" personnel approx 6 persons required from "Host" league to assist NASA Scrutineers.

### **"L & J" Nationals.**

East Anglia Rep. commented that all was proceeding.

"Brake testing" personnel approx 6 persons required from "Host" league to assist NASA Scrutineers.

The Club will be providing required personnel to assist NASA Scrutineers.

*Note. Pre-check sheets will be available for 2013 Nationals for competitors/officials.*

*They will be placed on NASA website shortly and also attached to website version of minutes for downloading.*

*2 pages per Class. First page = Main compliant sheet for "Signing of". Second Page = Items for checking and "signing off".*

*Alternatively League scrutineers that have been sent copies may forward on to competitors..*

### **d. Rules Clarification requests from League Scrutineers.**

*None specified in notes*

### **5. DRAFT RULE CHANGES:**

NASA Chief Scrutineer explained that the rule changes for 2014 had been agreed by the Board and will be included in minutes.

Due to approx 37 rules being affected by the introduction of the YARIS, the Class 1 info regarding YARIS will be placed on website.

a. Rule change requests from Leagues. –

*None specified in notes*

b. Rule change requests from Chief Scrutineer. – None additional to above.

*None specified in notes*

c. Rule change requests from Board of Directors. – None additional to above.

*None specified in notes*

### **6. ANY OTHER BUSINESS:**

*None specified in notes*

Meeting Closed 2.00 p.m.

N.B. REMINDERS:

1. **Next Meeting:**

2. **Rule Book & Licence.**

All members must be accompanied by their Rule Book and Licence at all times at a race meeting. Both the members Rule Book and Licence must be presented at “Scrutineering” and “Signing on” There must be a photograph of the member placed on the Licence.

4. **JUNIORS - Rule Book & Licence.**

All Junior Drivers must be accompanied by their Letter/Form of consent to race and Rule Book and Licence at all times at a race meeting.

The Letter/Form of Consent, Rule Book and Licence must be presented at “Scrutineering” and “Signing on”

There must be a photograph of the member placed on the Licence.

**“Orange” “Official” scrutineers jackets**

Not all “orange” “official” scrutineers jackets have been returned to Mr G. Jones following the National Championships. Could they please be returned as soon as possible.

**These jackets are intended for use at the National Championship Meetings only.**

They have not been generally issued to Clubs or Leagues for use locally.

If any are seen at race meetings then the Leagues concerned will be charged a certain sum of money and the jackets confiscated.

**2013 National Autograss Championships**

**Withington HR1 3QG**

**2<sup>nd</sup> 3<sup>rd</sup> & 4<sup>th</sup> August 2013**

Scrutineering times:  
(All to be confirmed)

**FRIDAY: Noise Testing**

**2.00 p.m. -- 3.30 p.m. (Break 3.30 - 4.30)  
4.30 p.m. -- 7.30 pm.**

**FRIDAY: Scrutineering**

**2.00 p.m. -- 4.00 p.m. (Break 4.00 – 5.00)  
5.00 p.m. -- 8.00 pm**

**SATURDAY: Noise Testing**

**7.30 a.m. -- 8.30 a.m.**

**SATURDAY: Scrutineering**

**8.00 a.m. -- 9.00 a.m.**

**SUNDAY: Scrutineering**

**8.30 a.m. -- 9.00 a.m. (Repaired vehicles only)**

**2013 Ladies & Junior National Autograss Championships**

**Wyboston MK44 3BE**

**30<sup>th</sup> 31<sup>st</sup> Aug & 1<sup>st</sup> September 2013**

Scrutineering times:  
(All to be confirmed)

**FRIDAY: Noise Testing**

**2.00 p.m. -- 3.30 p.m. (Break 3.30 - 4.30)  
4.30 p.m. -- 7.00 pm.**

**FRIDAY: Scrutineering**

**2.00 p.m. -- 4.00 p.m. (Break 4.00 – 5.00)  
5.00 p.m. -- 7.30 pm**

**SATURDAY: Noise Testing**

**7.30 a.m. -- 8.00 a.m.**

**SATURDAY: Scrutineering**

**7.30 a.m. -- 8.00 a.m.**

**SUNDAY: Scrutineering**

**8.30 a.m. -- 9.00 a.m.  
(Repaired vehicles only)**

**NOTE:**

Any scrutineer who wishes to take part in scrutineering duties at the NAC's must attend at least one scrutineers committee meeting.

## Proposed rules changes for January 2014

### Class 1

Incorporation of Yaris vehicles "Experimental rules" into various existing Class 1 rules – 37 No.

Roll Cage introduction - *Wording printed in duplicate. Deletion of duplication.*

Rule 6. *Comma printed in duplicate. Deletion of duplication.*

17.1 Suspension type is restricted.

The standard production suspension system must be retained. "Concentric Strut Top" mountings prohibited.

It is not permitted to **modify any wedge/gusset** suspension component **unless the alteration of the component concerned is specified within the rules.**

Nissan Micra 1.0 16V (CG10DE)

Rear Panhard rod (Panhard bar/Track bar) may be fitted with "Gusset" **and or reinforcing bar/plate** along lower edge **of the "U" section** only.

**The modification of panhard rod, including enabling it to become adjustable, is prohibited.**

**The replacing of the panhard rod by a non standard item or non-steel item is prohibited.**

*Rule amendments to clarify permitted modification of Micra panhard rod.*

### Class 2

3.5 Window Webbing/Net/Mesh.

The fitting of a system for the purpose of retaining the driver's arms and hands within the driver's compartment in the event of an accident or roll over is mandatory. See Rule 11.

If a arm restraint system is not used then a non-metal webbed/meshed net on the drivers door window aperture (Either wholly or partially), is mandatory and must be fitted. See Fig. 15.

~~If the driver is 'Centrally seated' within the vehicle then a window net on both nearside and offside drivers compartment window apertures must be fitted.~~

If an arm restraint system is used then the driver's compartment access window aperture(s) may also have a non-metal webbed/meshed net covering (Either wholly or partially).

*Class 2 – Central seated prohibited. Deletion of unnecessary duplication that exist in other modified classes.*

### Class 1,2,3,4,5,6, & 7.

8 All NASA permitted proprietary manufactured roll cages must comply with NASA design, complete with the correct proprietary manufactured additional bars (e.g. Door bars and Diagonals) fitted as required. All tube to be cold drawn seamless carbon steel, with a minimum yield strength of 350N/mm.

Permitted minimum diameter and tube wall thickness sizes:

**32 / 38 / 42mm Diameter with a absolute minimum wall thickness = 2.5mm.**

~~42mm Diameter with a minimum wall thickness = 2.5mm.~~

50mm Diameter with a **absolute** minimum wall thickness = 2.0mm.

See Figure 1 for roll cage design.

*Roll cage sizes – addition of 32mm to reflect actual sizes used by proprietary manufacturers.*

*Combination of 2 lines into 1 to reduce space.*

22 *Wording printed in duplicate. Deletion of duplication.*

3.5 Window Webbing/Net/Mesh.

c). 'Window net' form of construction must be only as permitted by NASA. The types of construction will be subject to regular review by NASA to ensure suitability for Autograss racing.

NASA reserves the right to amend the permitted 'Window net' construction requirements at any time.

(The use of Velcro fastenings will be monitored for suitability and reviewed in June 2013).

OMP & TRS & RJS Oblong and or Trapezoid (angular) full size window safety net permitted.

~~Randal Motorsport – Black Mesh Window Net and 'Head Net' permitted.~~

*Revision to permitted window webbing.*

### Class 1 & 2 & Jnr Sp

13.1 Wheels – Restricted.

All wheels must be in good order and or condition and be free of damage.

**Modification of a proprietary manufactured wheel by "Thinning" and or "Diameter reduction" and or "Grooving", "Slotting" or "Drilling" and or other machining is prohibited.**

*Safety rule clarifying and reinforcing existing prohibition of "Home" wheel modification required by Board.*

### Class 3, 4, 5, 6 & 7.

13.1 Wheels – Restricted.

All wheels must be in good order and or condition and be free of damage.

**Modification of a proprietary manufactured wheel by "Thinning" and or "Diameter reduction" and or "Grooving", "Slotting" or "Drilling" and or other "non-beadlock fitting" machining is prohibited.**

*Safety rule clarifying and reinforcing existing prohibition of "Home" wheel modification required by Board.*

10.5 A single "accelerator" or "throttle" pedal, including a "accelerator/throttle cable" must be fitted to control the operation of the fuel delivery system to the engine. ~~"Fly by wire" type systems prohibited.~~ The engine must be fitted an 'accelerator' or 'throttle' return spring such that the fuel delivery system closes once the 'accelerator' or 'throttle' pedal is released.

*Removal of wording as required by Board.*

**Class 8,9,10**

- 21.4 A single "accelerator" or "throttle" pedal, including a "accelerator/throttle cable" must be fitted to control the operation of the fuel delivery system to the engine or engines. ~~"Fly by wire" type systems prohibited.~~  
The use of "sub-pedals or devices" to independently control the fuel delivery to each engine in twin-engine installations is prohibited.  
All engines must be fitted with an 'accelerator' or 'throttle' return spring such that the fuel delivery system closes once the 'accelerator' or 'throttle' pedal is released

*Removal of wording as required by Board.*

**13.1 Wheels – Restricted.**

All wheels must be in good order and or condition and be free of damage.

Modification of a proprietary manufactured wheel by "Thinning" and or "Diameter reduction" and or "Grooving", "Slotting" or "Drilling" and or other "non-beadlock fitting" machining is prohibited.

*Safety rule clarifying and reinforcing existing prohibition of "Home" wheel modification required by Board.*

**Class Jnr Sp****10.9 Fuel Pump Type – Restricted.**

- i. The original donor vehicle fuel delivery pump may be retained or removed. A proprietary manufactured standard production GM Vauxhall or standard production replacement GM Vauxhall fuel pump must be fitted. It is permitted to use a standard production fuel pump from the GM Vauxhall Nova, Corsa, Astra or Cavalier range of road vehicles including the replacement fuel pump – Sytec FP603 (3 Bar). The use of a non-GM Vauxhall or non specified replacement pump or "Competition" or "Competition type" fuel pump is prohibited. See Rule 9.1

*Clarification of replacement fuel pump.*

**All Classes**

*Syntax corrections & Missing "Full Stops". – Approx 30 rules.*



1. Scrutineers must give all assistance required to drivers/constructors in preparing vehicles to comply with the 2013 Edition Rule Book.
2. For future reference: **WANTED:**  
Details, photographs, etc. of reasons for vehicles to fail scrutineering, examples of incorrect or dangerous practices.
- 3 **FUTURE MEETINGS: 11.00 am**  
**Travelodge, Birmingham Rd, Walsall WS5 3AB**

SATURDAY

13th OCTOBER

2013 Rules - Confirmation

**NASA AGM 25 November 2012**

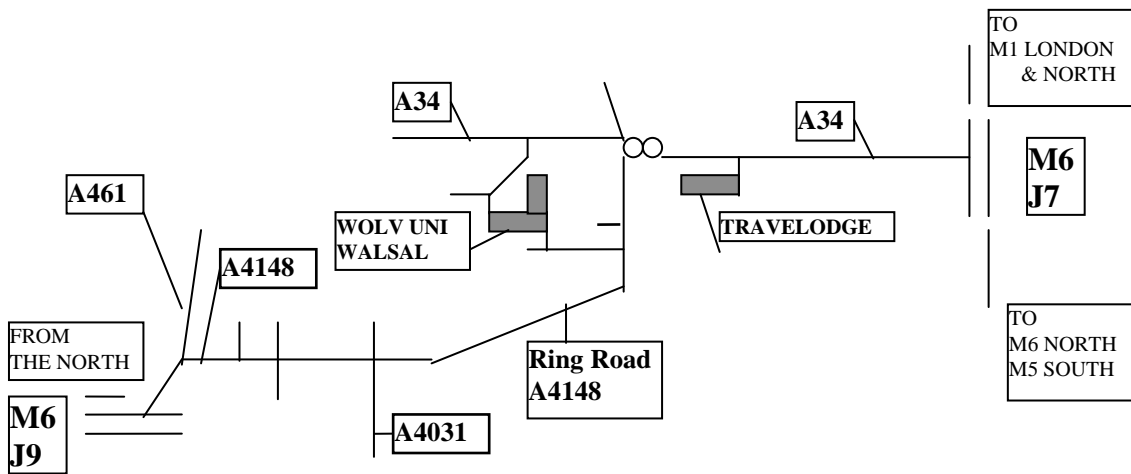

People attending the meeting must park their vehicles in CAR PARK. PLEASE DO NOT PARK ON THE GRASS. There is a £3 charge for parking.

Follow signs to RECEPTION, a porter will then direct you to the correct room.

**You are advised to bring your own refreshments.**

**The Travelodge has a NO-SMOKING rule.**

4. Comments required from leagues on:  
NASA Rules & Regulations - Clarification's, Changes for future etc.

=====

## 2013 NATIONAL AUTOGRASS CHAMPIONSHIPS - GENERAL SCRUTINEERING INFORMATION SHEETS.

The following is what is generally required at the NAC's.

The independent measurers for post final checking of vehicles, which should be available from 4.00pm to 12 Midnight on Sunday.

NAC:- Host League & NASA Officials.

Ladies & Junior NAC:- Host League & NASA Officials.

They will only measure and provide figures, actual engine cc is to be calculated by NASA Scrutineering Officials.

Also they will not necessarily measure the bore/stroke etc. of every vehicle, due to number of vehicles to be checked and short period of time available some measuring will be done by NASA Scrutineers, in the event of a dispute the independent measurer can check measurements taken by NASA Scrutineers. There is a temperature gauge available to obtain the temperature of the measured parts if necessary.

b). Scrutineering system.

As outlined in the NAC File with must be adhered to. Formal pre-checking of vehicles introduced.

**For the Men's NAC:-** 10 lanes are required, one per class - each lane to be 10 ft wide.

**For the Ladies & Jnr NAC:-** - Each scrutineering lane to be 10 ft wide and depending on the number of vehicles entered some classes may share lanes i.e. 2 Class 1 lanes, Class 2, Class 3 & 7, Class 4,5, & 6, Classes 8,9, & 10.

Where a vehicle is shared both drivers must be with vehicle when it is scrutineered. e.g. Class 1 Jnr. & Lady driver's. This to ensure the safety harness, crash helmet, seat, headrest etc. properly fit both driver's.

Both drivers must undergo a brake test.

Ambulance/First aid facilities to be available from start of scrutineering in case of injury/accidents in check lanes.

Scrutineering PASS stickers (pre-adhesived) for vehicles must be provided by host League, they are to be as NASA approved design and delivered to Scrutineers Secretary well in advance of start of scrutineering at each NAC.

**Scrutineering cannot begin until the stickers are available for use by the scrutineers.**

Host League scrutineers responsible for 1st safety check lane, under the control of Host League Chief Scrutineer.

Host League C. Scrutineer to be available at all times, with a league rep available to liaise as required throughout the meeting.

NASA scrutineers responsible for 2nd general check lanes, with National Scrutineers for lanes 1 - 5, and responsible for lanes 6 - 10, with NASA Chief Scrutineer in overall charge.

If any Scrutineer has a query the first contact is the National Scrutineer for the class involved, if answer cannot be given/agreed NASA Chief Scrutineer will be contacted to give final ruling.

**Scrutineering System - for Friday/Saturday checks the driver will be given the form at Bay 1 – Brake and safety checks, Scrutineers sign form state if passed/failed. If passed driver will present to Bay 2 scrutineer. Scrutineers checks vehicle. Once driver have been given a "Pass" the 'Bay 1 & 2' form is handed to signing on person.**

**If the driver loses the form then the vehicle will be completely re-scrutineered.**

**Sunday. If the vehicle is to be re-scrutineered for any reason then a new form will filled in accordingly and the vehicle re-checked using that form.**

Host League to provide a 'signing on' marshal at end of each 2nd check lanes. Also, each 'signing on' marshal to be provided (by Host League) with a suitable clipboard, pen, and container/plastic bag for scrutineering forms.

All 'Bay 1 & 2' scrutineering forms to be returned to Scrutineers Secretary after scrutineering ceases on each day.

If inclement weather forecasted then it is recommended that end of 2nd check lanes to be provided with waterproof covering. e.g. scaffolding and tarpaulin cover.

All 2nd check lanes shared i.e. not wholly manned by scrutineers from same league.

Scrutineers cannot check their qualified class, or that of their partner/child, if they or their partner/child is racing at the NAC's.

Driver to be in race trim i.e. with overalls, helmet on, vehicles to be without tools, spare wheels, jacks, etc.

### **VEHICLE IDENTIFICATION CLUB LETTERS & NUMBERS TO BE PLAIN BLACK ON WHITE PANEL - AS SHOWN ON DIAGRAM IN RULE BOOK.**

**(No shading, blocking, outlining, leaning, "Stock Car" styling, etc.).**

When dealing with drivers etc. all scrutineers must try to be as tactful and as helpful as possible.

If a driver is abusive, scrutineers can refuse to check his/her vehicle and the driver will be reported for disciplinary action by NASA.

Vehicles in doubt to be directed to one side, to prevent build up of queues etc.

**Marshals (minimum 10 No.) required from Host League to keep out Mechanics, Drivers family, friends, children and all other spectators etc.**

### **RESERVE vehicles may be scrutineered on the Friday evening.**

Reserve vehicles will be scrutineered, then directed to a separate holding area until they are informed whether they are required, Drivers are advised to stay with their vehicles.

Substitute vehicles must have the correct form with them otherwise they cannot be scrutineered. **SUBSTITUTE vehicles may be scrutineered on the Friday .**

Substitute vehicles will be directed to the pits.

Refreshments must be available to scrutineers from start of scrutineering, on Friday eve up to and including the end of Post Race scrutineering on Sunday evening.

Scrutineers will be given passes etc. Host League C. Scrutineers to check arrangements for refunds etc. to Officials at each NAC. NAC treasurers to liaise with Scrutineers Secretary regarding numbers of scrutineers eligible for refund.

**N.B. : All Scrutineers must pay the race meeting entry charges, unless they are given complementary tickets. Men's NAC: Scrutineers who "work" on Friday afternoon/eve only and disappear for rest of NAC's will not be eligible for refund.**

Separate camping will be provided for Officials including scrutineers, to allow minimum disturbance to other campers etc.

Camping site open : Ladies/Jnr NAC: **Wednesday** to **Tuesday**  
NAC: **Thursday** to **Thursday**

Host Leagues to confirm Officials camping areas & dates/times to all NASA Leagues etc.

The pits/vehicle storage areas:

These will be patrolled during the nights. For vehicles not racing at the Men's NAC's but racing locally after Men's NAC's a separate compound may be made available for storage, such vehicles will not be permitted to be stored in campsite. ---- Host League C. Scrutineer/L. Chairman to confirm & advise.

Scrutineers & Officials own vehicles to be given priority at scrutineering, as this will release them for scrutineering & official duties as soon as possible, otherwise unnecessary delays may occur.

Scrutineers vehicles will be checked by the NASA Chief Scrutineer and National Scrutineers.

All vehicles will have raced and therefore should be legal. Vehicles with major faults should not have qualified.

**Scrutineers to check qualified vehicles before the NAC's & ensure that defects were fixed.**

Should any vehicle fail completely to pass Pre - Race scrutineering all defects must be listed in both the Licence and Rule Book of the driver, this will prevent such vehicles racing until faults corrected.

The welding bay costs must be on display, e.g. cost per foot of metal, etc. and will be reasonable.

Class 2 restrictors will be paint sealed at pre-race scrutineering.

#### **Post Race Scrutineering:**

Ambulance/First aid facilities to be available in case of injury/accidents in scrutineering area.

Marshals to be provided by host league to keep spectators etc. out of scrutineering areas.

Those attending including competitors, mechanics, must sign the attendance sheet for identification purposes.

Badges will be provided for post race scrutineering, in order to identify those people that are entitled to be there, all others will be told to leave the checking area.

Marquee will be provided for scrutineers, with tables & chairs and plywood floor etc.

Following to be provided:-

Engine hoist - 2 No to be provided by host league.  
Sturdy Benches for engines.  
Lighting for evening use.  
Containers/boxes required for waste oil, parts etc.  
Rags etc. to be provided.

A few tools to be provided by host league.

All must be marked as property of host league to prevent them going "missing". Some items have disappeared at previous NAC's. i.e.

- |                          |                                    |                         |
|--------------------------|------------------------------------|-------------------------|
| a) Mini flywheel puller. | b) 2 No. Valve spring compressors. | c) Spark plug spanners. |
| d) Hammer.               | e) Set Screwdrivers                | f) Set Metric spanners. |
| g) Set AF spanners.      | h). 32mm socket for Mini.          |                         |

Scrutineers to keep vehicles under observation; - to prevent drivers altering/removing illegal items. etc.

Independent measurer - provided by Host league. - see earlier discussion.

Strip downs - Depending on time available, type of engines and weather conditions etc.

All finalists in Class 1.

All finalists in Class 2 will have their restrictors checked and bore/stroke & Palgrave checks as required.

If conditions and time etc caused the all Class 2 Finalists to be not checked the remainder will be sealed.

First and second in class 3, 4, 5, 8 & 9 will have bore/stroke check and or be sealed.

Second in the above classes is checked as a precaution in case the first place vehicle is found not to comply with the cc rules.

First in Class 6, 7, &10. - Depending on types of engines.

The principal Class Scrutineers must be with the respective class vehicles during post race scrutineering.

**N.B. Vehicle driver & mechanic to provide own tools(including any specialist tools required) and remove items as directed by scrutineers.**

**Vehicles must be checked prior to removal from race meeting, otherwise any prizes etc. will be forfeited.**

**Abuse from Driver/mechanic, families, club/league officials will be noted and passed on to NASA Directors for disciplinary action.**

**If a driver/mechanic persists in being abusive the Scrutineering Officials can refuse to proceed with the check, and the vehicle will be deemed illegal, and all prizes forfeit.**

There may be NASA Directors in the area to observe, in order that they glean a clear picture of events to assist them in making decisions should any vehicle be reported to them for irregularities, and if there are any appeals.

Should any vehicle fail Post - Race scrutineering all defects must also be listed in both the Licence and Rule Book of the driver, this will prevent such vehicles racing until faults corrected (see also reference to form VL1).

All scrutineers etc; to emphasise the above to qualified drivers in own leagues.

The same system of post race scrutineering forms would be used as in previous years.  
This involved the issue of various forms to the drivers of vehicles attending post race scrutineering.

**Form D1:**

Will be issued to drivers of vehicles found not to comply with rules, listing faults and stating that vehicle cannot be raced again until it complies with rules.

**Racing under appeal".**

At NASA events there is no such thing as 'Racing under appeal', if a vehicle has been reported for failing post race scrutineering then it **CANNOT** race at **ANY** race meeting until the defects have been corrected, and form VL1 filled in.

**Form VL1.**

Will be issued with form D1, to be filled in by local League Chief Scrutineer once vehicle has been checked and found to comply with rules.  
There is a tear off strip at bottom of form to be returned to Scrutineers Secretary for information.

The remaining part of the form to be retained by the driver and kept with his licence to be produced at scrutineering every time the vehicle is raced until the end of the year.

(This to prove to others that any faults found have been corrected to prevent the driver being "victimised" at race meetings following the NAC's)

**Form AP1.**

Is issued with form D1 and VL1 should the driver wish to appeal, to be returned to NASA Secretary within 7 days.

Copies of any of the above issued at the NAC's will be passed to NASA Secretary and Local League Chairmen etc.

**Form CL1.**

For legal vehicles, drivers will be given this form for claiming oil allowance and cost of gaskets.  
To be returned to NASA Secretary complete with receipt for gaskets within 7 days.

**N.B. The gasket costs will only be paid for vehicles stripped on the day on the field.  
Up to a maximum of : Class 1 & 2 £50, Class 3 - 10 £50.  
Oil allowance of: All Classes - £20.**

**Where a driver insists on having the engine checked at the vehicle's owners garage/engine builders premises, the driver must pay in advance the NASA approved scrutineers travelling costs, at the NASA approved rate per mile.**

**This check must be done within 14 days of the NAC concerned.**

**If the driver refuses to pay, the vehicle will be deemed as being illegal and all prizes forfeit.**

**The driver may subject to the NASA Directors and the NASA Chief Scrutineer's approval, be checked at the NASA approved scrutineers premises.**

**CLASS SCRUTINEERS:**

**Orange Officials Jackets:**

Any jackets "borrowed" at previous years NAC's be returned at this years NAC's please. Some have been seen in use at various League Open meetings.

**Leagues will be charged for them if not returned.**

**Scrutineers.**

A letter is sent in April/May to each League Chief Scrutineer requesting names, for duties at the NAC's. The listing shown is based on returned information.

**Scrutineering:**

MEN'S	(All to be confirmed)	LADIES & JUNIOR	(All to be confirmed)
FRIDAY: Noise Testing	2.00 pm – 3.30 p.m.	FRIDAY: Noise Testing	2.00 pm – 3.30 p.m.
FRIDAY: Scrutineering	2.00 pm -- 4.00 p.m.	FRIDAY: Scrutineering	2.00 pm – 4.00 p.m.
	5.00 pm -- 8.00 p.m.		5.00 pm – 7.30 p.m.
SATURDAY: Noise Testing	7.30 am – 8.30 am	SATURDAY: Noise Testing	7.30 am – 8.00 am
SATURDAY: Scrutineering	8.00 am – 9.00 am	SATURDAY: Scrutineering	7.30 am – 8.30 am
SUNDAY: Noise Testing	As required	SUNDAY: Noise Testing	As required
SUNDAY: Scrutineering	8.30 am -- 9.00 am (Repaired vehicles only)	SUNDAY: Scrutineering	8.30 am -- 9.00 am (Repaired vehicles only)

Bay 1: Host League members: Host Leagues to forward list of names a.s.a.p. Minimum = 6 Scrutineers & 4 Marshals Total = 10.  
 Bay 2 Host League members: "Signing On" personnel - Minimum = 1 per lane Total = 10.

**Bay 2 : NASA CLASS SCRUTINEERS LIST PROVISIONAL**

	<u>MEN'S</u>		<u>LADIES &amp; JNR</u>	
CLASS	SCRUTINEER	CLUB/LEAGUE	SCRUTINEER	CLUB/LEAGUE
<b>1</b>	V. Wallis	SS	V. Wallis	SS
	M. Lane	M	M. Lane	M
	S. Knott	YD	S. Knott	YD
	K. Bowman	SN	K. Bowman	SN
<b>2</b>	M. Bevans	WW	M. Bevans	WW
	R. Lillington	S	R. Lillington	S
	B. Lewis	Pac	B. Lewis	Pac
	M. Uka	Pac	M. Uka	Pac
<b>3</b>	J. Mason	BH	J. Mason	BH
	Dave Digby	E. ANGLIA	Dave Digby	E. ANGLIA
	R. Simmonds	L	R. Simmonds	L
	D. George	SN	D. George	SN
<b>4</b>	K Jones	SW	K Jones	SWL
	N. Lewis	Pac	N. Lewis	Pac
	G. Major	Pen	G. Major	Pen
	<i>A.N. Other</i>		<i>A.N. Other</i>	
<b>5</b>	J Knipe	CGTRO	J Knipe	CGTRO
	D. Creed	BH	<i>A.N. Other</i>	
	<i>A.N. Other</i>		<i>A.N. Other</i>	
	<i>A.N. Other</i>		<i>A.N. Other</i>	
<b>6</b>	R. Corbett	Pac	R. Corbett	Pac
	N.Reed	SW	N. Reed	SWL
	M. James	Cm	M. James	Cm
	<i>A.N. Other</i>		<i>A.N. Other</i>	
<b>7</b>	G. Bennetto	GLOS	G. Bennetto	GLOS
	G. Pemberton	CA	G. Pemberton	CA
	I Fay	WS	I. Fay	WS
	D. Neville	Ca	D. Neville	Ca
<b>8</b>	A Cooper	SC		
	P. Cooper	NW	<b>J.Sp</b>	
	T. Allen	EM	K. Taylor	CA
	<i>A.N. Other</i>		<i>A.N. Other</i>	
<b>9</b>	R. Jones	NW		
	A. Heath	P.EM		
	K. Taylor	CA	<b>8/9/10</b>	
	<i>A.N. Other</i>		R. Hazard	S/CGTRO
<b>10</b>	R. Hazard	S/CGTRO	S. Rawsthorne	Nott
	S. Rawsthorne	Nott	A. Heath	P.EM
	<i>A.N. Other</i>		T. Allen	EM
	<i>A.N. Other</i>			
<b>NOISE:</b>	G. Makar	ST/CGTRO	L. Makar	ST/CGTRO
	P. Pearce		A.N. Other	

Other Scrutineers are required to replace 'A.N. Other' and welcome to turn up on day & volunteer.

**Note.**

Each Scrutineer will be given refund & award to commemorate work at NAC's.

Scrutineers to remain within allocated lanes. They must not congregate around vehicles in neighbouring lanes. This may give a mistaken impression that the vehicles concerned are illegal when they may be not.

**ROLL CAGES** :- Random checks to be done in Bay 2.

ROLL CAGE checks to be random as it is not practical to check every bar on every roll cage. Also local scrutineers should have already checked them.

The list is provisional, there will be a meeting of scrutineers at approx. 1.45 p.m. on Friday eve to confirm class allocation, as not all scrutineers listed may be available.

If any other scrutineers not mentioned wish to help at the NAC's then would they please contact Scrutineers Secretary as soon as possible.

**Class 2:**

All restrictors will be paint sealed in Bay 2. The seals cannot be broken without the presence of a Class 2 Scrutineer. If a seal is found to be broken without authorisation then the vehicle will immediately be disqualified from the NAC.

**Duty Scrutineers:**

There will be two scrutineers on duty at all time during the NAC's, to re-scrutineer vehicles following accidents, roll over's etc. They will be picked for a 2 hourly shift basis on each day.

De brief Meeting:

After each scrutineering session there will be a short meeting of scrutineers to discuss problems etc. at the NAC's.

**Start-line:**

As each Class is in the in the starting bay area, there will be the Class scrutineers available to ensure that helmets, and safety harnesses are a good fit on the driver, and to check that the vehicles have not been subject to an illegal modification to gain advantage etc. e.g. removal of silencers. Scrutineers whose Class is not in the areas must not congregate in the Start-line areas.

Repairs to vehicles cannot be done in Start-line area.

Host League to ensure that there are enough Start-line personnel to line up vehicles etc. in the past scrutineers have often ended up doing it.

**Re-run lane: Repairs to vehicles:**

The Chief Marshal agrees repairs will only be done in the re-run lane, within his specified time limit. Only Driver and 1 Mechanic allowed. If the vehicle is not ready then the re-run will continue without affected vehicle. Also any vehicle needing major repairs as a result of taking part in a race must be re-scrutineered following repair and before being permitted to enter re-run or any other race.

**NOISE: - Noise tests will be carried out.**

Person responsible for noise testing is to be confirmed. A team of approx. 3 helpers is required for the NAC's.

There will also be random noise tests upon vehicles during the race meeting.

There will be no tolerance on the NASA set noise level of 102 dBA.

It was pointed out that at previous NAC's certain drivers had altered their exhausts after passing the noise test but prior to a race to remove or amend modifications necessary to pass the noise tests.

**ANY DRIVER DOING THIS WILL BE IMMEDIATELY DISQUALIFIED FROM THE RACE HEAT or FINAL CONCERNED.**

**Also the chief marshal may request a noise check for certain vehicles as they leave the race track to enter the pits. If they are found to be above the noise limit they will be disqualified from that race.**

To ensure that there are no failures due to excessive noise it is recommended that vehicles are tested at local level, any vehicles found to be on the limit are encouraged to increase the amount silencing fitted.

**NOISE:**

- i. Recommended that all start line scrutineers/personnel wear ear defenders/ear plugs as the noise levels can be above a limit of 90 dBA/per hour, which if a person is continually exposed to may cause permanent hearing damage.
- ii. Classes 7, 8 and 10 particularly motorbike engined vehicles have been found to be close to or above the limits, the original bike engine silencer is not always sufficient to ensure compliance with noise limit. This to be drawn to the attention of the vehicles driver's.

**HEADRESTRAINTS:**

- i. Particular attention will be paid to head restraints for all vehicles, please ensure compliance to rules for all vehicles, including those fitted with high back competition type seats. The head restraint of such seats is not always high enough and an additional head restraint may need to be fitted, this is easier to do at home, rather than in a panic at the NAC's.

**NOTE.** The practise of allowing temporary modifications to enable head restraints to comply will not be permitted.

**2013 National Championships Vehicle Scrutineering Pre- Check Sheets.**

NASA - NATIONAL CHAMPIONSHIPS -- SCRUTINEERING PRE-CHECK LIST - 2013

**CLASS:** 1 JNR

DRIVER NAME..... LICENCE No.....

VEHICLE NUMBER..... DATE: .....

**\* CHECK LICENCE AND RULE BOOK FOR PREVIOUSLY LISTED FAULTS / COMMENTS \***

<b>NOISE TEST</b> MAX = 102 Db (A)	<b>PASS</b>	<b>COMMENTS</b>
NOISE READING _____ Db (A) @ _____ REVS / MIN		

<b>GENERAL INSPECTION ITEMS</b> AS LISTED ON INSPECTION SCHEDULE ON NEXT PAGE	<b>PASS</b>	<b>COMMENTS</b>

<b>NOISE TEST &amp; GENERAL INSPECTION ITEMS</b>	<b>FAIL</b>	<b>COMMENTS</b>

I certify that I have examined the above vehicle and have issued a **PASS / FAIL** as noted above.

LEAGUE CHIEF SCRUTINEER \_\_\_\_\_ Tel: \_\_\_\_\_

I certify that the above scrutineer has examined the above vehicle and issued a **PASS / FAIL** as noted above.

LEAGUE CHAIR \_\_\_\_\_ Tel: \_\_\_\_\_

For "PASS" THE FORM and INSPECTION SCHEDULE TO BE RETAINED BY COMPETITOR AND HANDED IN TO BAY 2 CLASS SCRUTINEER AT NAC  
If not presented then vehicle will be completely re-scrutineered at NAC.

The vehicle must be subject to the BAY 1 safety check at the NAC before proceeding to BAY 2.

For "FAIL" FORM TO BE RETAINED BY COMPETITOR UNTIL VEHICLE FAULTS HAVE BEEN REMEDIED AND VEHICLE RE-SCRUTINEERED AND A "PASS" ISSUED.

**NOTES**

It is the competitor's responsibility to ensure that the vehicle concerned complies with the NASA vehicle construction regulations. The original checked vehicle cannot be substituted by the use of another vehicle, unless authorised by the League Chair concerned. The substitute vehicle must be inspected and checked for compliance and seperately certified.

It is the League Chief Scrutineer's responsibility to ensure that the items listed have been checked for compliance with the NASA vehicle construction regulations in accordance with the NASA Scrutineering procedures.

It is the League Chair's responsibility to ensure that the items listed have been checked for compliance with the NASA vehicle construction regulations in accordance with the NASA Scrutineering procedures.

Random checks will be made at National Autograss Championship (NAC) to check validity of inspection schedule. Possession of form does not exempt vehicle from further scrutineering inspection.

Where the certification of compliance with the construction rules is found to be false and or an unauthorised vehicle substituted the competitor and/or driver of the vehicle concerned shall be disqualified and will be reported for disciplinary action. The Scrutineer and League Chair will also be reported.





**NASA - NATIONAL CHAMPIONSHIPS -- SCRUTINEERING PRE-CHECK LIST - 2013**

**CLASS:** 1

DRIVER NAME..... LICENCE No.....

VEHICLE NUMBER..... DATE: .....

**\* CHECK LICENCE AND RULE BOOK FOR PREVIOUSLY LISTED FAULTS / COMMENTS \***

<b>NOISE TEST</b>	<b>PASS</b>	<b>COMMENTS</b>
MAX = 102 Db (A)		
NOISE READING _____ Db (A) @ _____		REVS / MIN

<b>GENERAL INSPECTION ITEMS</b>	<b>PASS</b>	<b>COMMENTS</b>
AS LISTED ON INSPECTION SCHEDULE ON NEXT PAGE		

<b>NOISE TEST &amp; GENERAL INSPECTION ITEMS</b>	<b>FAIL</b>	<b>COMMENTS</b>

I certify that I have examined the above vehicle and have issued a **PASS / FAIL** as noted above.

LEAGUE CHIEF SCRUTINEER \_\_\_\_\_ Tel: \_\_\_\_\_

I certify that the above scrutineer has examined the above vehicle and issued a **PASS / FAIL** as noted above.

LEAGUE CHAIR \_\_\_\_\_ Tel: \_\_\_\_\_

For "PASS" THE FORM and INSPECTION SCHEDULE TO BE RETAINED BY COMPETITOR AND HANDED IN TO BAY 2 CLASS SCRUTINEER AT NAC  
If not presented then vehicle will be completely re-scrutineered at NAC.

The vehicle must be subject to the BAY 1 safety check at the NAC before proceeding to BAY 2.

For "FAIL" FORM TO BE RETAINED BY COMPETITOR UNTIL VEHICLE FAULTS HAVE BEEN REMEDIED AND VEHICLE RE-SCRUTINEERED AND A "PASS" ISSUED.

**NOTES**

It is the competitor's responsibility to ensure that the vehicle concerned complies with the NASA vehicle construction regulations. The original checked vehicle cannot be substituted by the use of another vehicle, unless authorised by the League Chair concerned. The substitute vehicle must be inspected and checked for compliance and seperately certified.

It is the League Chief Scrutineer's responsibility to ensure that the items listed have been checked for compliance with the NASA vehicle construction regulations in accordance with the NASA Scrutineering procedures.

It is the League Chair's responsibility to ensure that the items listed have been checked for compliance with the NASA vehicle construction regulations in accordance with the NASA Scrutineering procedures.

Random checks will be made at National Autograss Championship (NAC) to check validity of inspection schedule. Possession of form does not exempt vehicle from further scrutineering inspection.

Where the certification of compliance with the construction rules is found to be false and or an unauthorised vehicle substituted the competitor and/or driver of the vehicle concerned shall be disqualified and will be reported for disciplinary action. The Scrutineer and League Chair will also be reported.



**NASA - NATIONAL CHAMPIONSHIPS -- SCRUTINEERING PRE-CHECK LIST - 2013**

**CLASS:** 2

DRIVER NAME..... LICENCE No.....

VEHICLE NUMBER..... DATE: .....

**\* CHECK LICENCE AND RULE BOOK FOR PREVIOUSLY LISTED FAULTS / COMMENTS \***

<b>NOISE TEST</b> MAX = 102 Db (A)	<b>PASS</b>	<b>COMMENTS</b>
NOISE READING _____	Db (A) @ _____	REVS / MIN _____

<b>GENERAL INSPECTION</b> AS LISTED ON INSPECTION SCHEDULE ON NEXT PAGE	<b>PASS</b>	<b>COMMENTS</b>
---	-------------	-----------------

<b>NOISE TEST &amp; GENERAL INSPECTION</b> ITEMS	<b>FAIL</b>	<b>COMMENTS</b>

I certify that I have examined the above vehicle and have issued a **PASS / FAIL** as noted above.

LEAGUE CHIEF SCRUTINEER \_\_\_\_\_ Tel: \_\_\_\_\_

I certify that the above scrutineer has examined the above vehicle and issued a **PASS / FAIL** as noted above.

LEAGUE CHAIR \_\_\_\_\_ Tel: \_\_\_\_\_

For "PASS" THE FORM and INSPECTION SCHEDULE TO BE RETAINED BY COMPETITOR AND HANDED IN TO BAY 2 CLASS SCRUTINEER AT NAC  
If not presented then vehicle will be completely re-scrutineered at NAC.

The vehicle must be subject to the BAY 1 safety check at the NAC before proceeding to BAY 2.

For "FAIL" FORM TO BE RETAINED BY COMPETITOR UNTIL VEHICLE FAULTS HAVE BEEN REMEDIED AND VEHICLE RE-SCRUTINEERED AND A "PASS" ISSUED.

**NOTES**

It is the competitor's responsibility to ensure that the vehicle concerned complies with the NASA vehicle construction regulations. The original checked vehicle cannot be substituted by the use of another vehicle, unless authorised by the League Chair concerned. The substitute vehicle must be inspected and checked for compliance and seperately certified.

It is the League Chief Scrutineer's responsibility to ensure that the items listed have been checked for compliance with the NASA vehicle construction regulations in accordance with the NASA Scrutineering procedures.

It is the League Chair's responsibility to ensure that the items listed have been checked for compliance with the NASA vehicle construction regulations in accordance with the NASA Scrutineering procedures.

Random checks will be made at National Autograss Championship (NAC) to check validity of inspection schedule. Possession of form does not exempt vehicle from further scrutineering inspection.

Where the certification of compliance with the construction rules is found to be false and or an unauthorised vehicle substituted the competitor and/or driver of the vehicle concerned shall be disqualified and will be reported for disciplinary action. The Scrutineer and League Chair will also be reported.



NASA - NATIONAL CHAMPIONSHIPS -- SCRUTINEERING PRE-CHECK LIST - 2013

**CLASS:** 3

DRIVER NAME..... LICENCE No.....

VEHICLE NUMBER..... DATE: .....

**\* CHECK LICENCE AND RULE BOOK FOR PREVIOUSLY LISTED FAULTS / COMMENTS \***

<b>NOISE TEST</b> MAX = 102 Db (A)	<b>PASS</b>	<b>COMMENTS</b>
NOISE READING _____ Db (A) @ _____ REVS / MIN		

<b>GENERAL INSPECTION</b> AS LISTED ON INSPECTION SCHEDULE ON NEXT PAGE	<b>PASS</b>	<b>COMMENTS</b>
<b>ITEMS</b>		

<b>NOISE TEST &amp; GENERAL INSPECTION</b> <b>ITEMS</b>	<b>FAIL</b>	<b>COMMENTS</b>

I certify that I have examined the above vehicle and have issued a **PASS / FAIL** as noted above.

LEAGUE CHIEF SCRUTINEER \_\_\_\_\_ Tel: \_\_\_\_\_

I certify that the above scrutineer has examined the above vehicle and issued a **PASS / FAIL** as noted above.

LEAGUE CHAIR \_\_\_\_\_ Tel: \_\_\_\_\_

For "PASS" THE FORM and INSPECTION SCHEDULE TO BE RETAINED BY COMPETITOR AND HANDED IN TO BAY 2 CLASS SCRUTINEER AT NAC  
If not presented then vehicle will be completely re-scrutineered at NAC.

The vehicle must be subject to the BAY 1 safety check at the NAC before proceeding to BAY 2.

For "FAIL" FORM TO BE RETAINED BY COMPETITOR UNTIL VEHICLE FAULTS HAVE BEEN REMEDIED AND VEHICLE RE-SCRUTINEERED AND A "PASS" ISSUED.

**NOTES**

It is the competitor's responsibility to ensure that the vehicle concerned complies with the NASA vehicle construction regulations. The original checked vehicle cannot be substituted by the use of another vehicle, unless authorised by the League Chair concerned. The substitute vehicle must be inspected and checked for compliance and seperately certified.

It is the League Chief Scrutineer's responsibility to ensure that the items listed have been checked for compliance with the NASA vehicle construction regulations in accordance with the NASA Scrutineering procedures.

It is the League Chair's responsibility to ensure that the items listed have been checked for compliance with the NASA vehicle construction regulations in accordance with the NASA Scrutineering procedures.

Random checks will be made at National Autograss Championship (NAC) to check validity of inspection schedule. Possession of form does not exempt vehicle from further scrutineering inspection.

Where the certification of compliance with the construction rules is found to be false and or an unauthorised vehicle substituted the competitor and/or driver of the vehicle concerned shall be disqualified and will be reported for disciplinary action. The Scrutineer and League Chair will also be reported.

**CLASS 3 NASA - NATIONAL CHAMPIONSHIPS -- SCRUTINEERING PRE-CHECK LIST - 2013**

**\* CHECK LICENCE AND RULE BOOK FOR PREVIOUSLY LISTED FAULTS / COMMENTS \***

No.	GENERAL	P	F
1	NOISE + BRAKE TEST PASS STICKER.....		
2	IDENTIFICATION OK.....		
3	CLARITY OF NUMBERS/LETTERS.....		
4	BLACK ON WHITE PANEL / UPRIGHT.....		
5	BODYSHELL ORIG RWD SAL/H'BACK ..... OR APPROVED FWD CONVERSION.....		
6	BODYSHELL COMPLETE.....		
7	TAILGATE/BOOTLID,VALANCE, WINGS.....		
8	ORIGINAL ENGINE COVER/BONNET.....		
9	STD REPLACEMENT PANELS.....		
10	CORRECT SKINNING.....		
11	NO REINFORCEMENT.....		
12	AIR COOLING HOLES OK.....		
13	ALL DOORS WELDED.....		
14	DRIVER'S DOOR MN'RD HEIGHT.....		
15	PASS'NGR DOORS 3/4 MN'RD HGHT.....		
16	TOWING EYE 50mm @ FRONT + REAR.....		
17	SCREEN MESH 1" * 1"(25mm * 25mm).....		
18	PERSPEX OUTSIDE FRONT SCREEN ONLY.....		
19	ROLL CAGE DESIGN + FIT OK.....		
20	DOOR BARS/BRACE BARS OK.....		
21	ROLL CAGE NOT MEDIUM FOR WATER /ELECTRICS.....		
22	ROLL CAGE NASA FULLY WELDED.....		
23	ROLL CAGE INTEGRAL FLOOR FRAME.....		
24	ROLL CAGE FEET / F Fm PLATED.....		
25	NO FRONT PROTECTION.....		
26	REAR BUMPERS / PROTECTION OK.....		
27	FRONT BUMPERS + SUP'T BAR OK.....		
28	BALLAST TYPE OK.....		
29	BATTERY CUT OFF SWITCH WORKING.....		
30	BATTERY BOX TYPE & SIZE OK.....		
31	FUEL TANK 2 GALL MAX.....		
32	TAP IF FITTED INTEGRAL.....		
33	VENT PIPE TO BELOW FLOOR.....		
34	FIRE HOLE IF ENCLOSED.....		
35	NO FUEL/OIL/WATER LEAKS.....		
36	WHEELS & TYRES COVERED 2"(50mm).....		
37	WHEEL STUDS FULL NUT THREAD.....		
38	WHEELS - CENTRE NOT CRACKED + RIM OK - NO DAMAGE.....		
39	WHEEL SPACERS ONE PIECE SOLID.....		
40	TYRES Option 'A' or 'B' only.....		
41	TYRES - NO BULGES/CUTS.....		
42	SECONDARY FASTENINGS OK.....		
43	NO SHARP PROJECTIONS.....		
44	NO TRACTION CONTROL.....		

No.	DRIVERS COMPARTMENT	P	F
45	CRASH HELMET BS NUMBERS.....		
46	CRASH HELM'T NOT PAINTED, 47 STICKERED, DAMAGED.....		
48	ROLL CAGE 3" (75mm) ABOVE HELMET.....		
49	SAFETY HARNESS MIN 5 PT FIX.....		
50	NOT CUT/DAMAGED,BUCKLE OK.....		
51	HEAD RESTRAINT.....		
52	ARM RESTRAINT SYSTEM OK.....		
53	SEAT CORRECT.....		
54	SEAT SUPPORT+MOUNTINGS.....		
55	FIRE EXTINGUISHER CORRECT.....		
56	FIXED & WITHIN DRIVER REACH.....		
57	IGN SWITCH WITHIN DRIVER REACH.....		
58	STEERING FRONT WHEELS ONLY.....		
59	ORIGINAL or STEEL FRONT BULKHEAD COMPLETE.....		
60	NO HOLES.....		
61	ORIGINAL or STEEL TRANSMISSION TUNNEL COMPLETE NO HOLES.....		
62	ORIGINAL or STEEL FLOORPAN & BOOT FLOOR COMPLETE NO HOLES...		
63	FLOOR FRAME OK.....		
64	LOWER X MEMBER 38mm X 38mm.....		
65	EXHAUST THRU' BULKHEAD OK.....		
66	EXHAUST TO REAR, EXIT OK.....		
67	EXHAUST SHIELDED.....		
68	FUEL TANK OK & SHIELDED.....		
69	FUEL/OIL/WATER PIPES COVERED.....		
70	ENGINE TYPE - 2V/4V CYL OK.....		
71	ENGINE NOT M'BIKE DERIVED.....		
72	ENGINE LOCATION - No1 PLUG + FRONT HUBS RELATIONSHIP OK.....		
73	NO TURBO / SUPERCHARGER.....		
74	CARB / Finj RETURN SPRING.....		
75	BONNET/ENGINE COVER ST'D.....		
76	BULGE/AIR BOX OK.....		
77	INNER WINGS (Orig. RWD) OK.....		
78	GEARBOX/AXLE Type OK.....		
79	ENGINE to G'BOX AD'PTOR 350mm OK.....		
80	NO TRANSAXLE.....		
81	AXLE LOCATION OK.....		
82	DIFF LOCATION OK.....		
83	REAR WHEEL HUBS LOCATION OK.....		
84	WHEELBASE OK.....		

CAR NO ..... N.A.S.A. LEAGUE .....

PASS..... FAIL..... LEAGUE CHIEF SCRUTINEER.....

FORM TO BE RETAINED BY COMPETITOR AND PRESENTED AT NAC

NASA - NATIONAL CHAMPIONSHIPS -- SCRUTINEERING PRE-CHECK LIST - 2013

**CLASS:** 4

DRIVER NAME..... LICENCE No.....

VEHICLE NUMBER..... DATE: .....

**\* CHECK LICENCE AND RULE BOOK FOR PREVIOUSLY LISTED FAULTS / COMMENTS \***

<b>NOISE TEST</b> MAX = 102 Db (A)	<b>PASS</b>	<b>COMMENTS</b>
NOISE READING _____ Db (A) @ _____ REVS / MIN		

<b>GENERAL INSPECTION</b> AS LISTED ON INSPECTION SCHEDULE ON NEXT PAGE	<b>PASS</b>	<b>COMMENTS</b>
<b>ITEMS</b>		

<b>NOISE TEST &amp; GENERAL INSPECTION</b> <b>ITEMS</b>	<b>FAIL</b>	<b>COMMENTS</b>

I certify that I have examined the above vehicle and have issued a PASS / FAIL as noted above.

LEAGUE CHIEF SCRUTINEER \_\_\_\_\_ Tel: \_\_\_\_\_

I certify that the above scrutineer has examined the above vehicle and issued a PASS / FAIL as noted above.

LEAGUE CHAIR \_\_\_\_\_ Tel: \_\_\_\_\_

For "PASS" THE FORM and INSPECTION SCHEDULE TO BE RETAINED BY COMPETITOR AND HANDED IN TO BAY 2 CLASS SCRUTINEER AT NAC  
If not presented then vehicle will be completely re-scrutineered at NAC.

The vehicle must be subject to the BAY 1 safety check at the NAC before proceeding to BAY 2.

For "FAIL" FORM TO BE RETAINED BY COMPETITOR UNTIL VEHICLE FAULTS HAVE BEEN REMEDIED AND VEHICLE RE-SCRUTINEERED AND A "PASS" ISSUED.

**NOTES**

It is the competitor's responsibility to ensure that the vehicle concerned complies with the NASA vehicle construction regulations. The original checked vehicle cannot be substituted by the use of another vehicle, unless authorised by the League Chair concerned. The substitute vehicle must be inspected and checked for compliance and seperately certified.

It is the League Chief Scrutineer's responsibility to ensure that the items listed have been checked for compliance with the NASA vehicle construction regulations in accordance with the NASA Scrutineering procedures.

It is the League Chair's responsibility to ensure that the items listed have been checked for compliance with the NASA vehicle construction regulations in accordance with the NASA Scrutineering procedures.

Random checks will be made at National Autograss Championship (NAC) to check validity of inspection schedule. Possession of form does not exempt vehicle from further scrutineering inspection.

Where the certification of compliance with the construction rules is found to be false and or an unauthorised vehicle substituted the competitor and/or driver of the vehicle concerned shall be disqualified and will be reported for disciplinary action. The Scrutineer and League Chair will also be reported.



CLASS 4 NASA - NATIONAL CHAMPIONSHIPS -- SCRUTINEERING PRE-CHECK LIST - 2013

\* CHECK LICENCE AND RULE BOOK FOR PREVIOUSLY LISTED FAULTS / COMMENTS \*

No.	GENERAL	P	F
1	NOISE + BRAKE TEST PASS STICKER.....		
2	IDENTIFICATION OK.....		
3	CLARITY OF NUMBERS/LETTERS.....		
4	BLACK ON WHITE PANEL / UPRIGHT.....		
5	BODYSHELL COMPLETE.....		
6	TAILGATE/BOOTLID,VALANCE, WINGS.....		
7	ORIGINAL ENGINE COVER/BONNET.....		
8	STD REPLACEMENT PANELS.....		
9	CORRECT SKINNING .....		
10	NO REINFORCEMENT.....		
11	FLICH PANEL REMOVED 1" BOX.....		
12	AIR COOLING HOLES OK.....		
13	ALL DOORS WELDED.....		
14	DRIVER'S DOOR MNF'RD HEIGHT.....		
15	PASS'NGR DOORS 3/4 MNF'R HGHT.....		
16	TOWING EYE 50mm @ FRONT + REAR.....		
17	SCREEN MESH 1" * 1"(25mm * 25mm).....		
18	PERSPEX OUTSIDE FRONT SCREEN ONLY.....		
19	ROLL CAGE DESIGN + FIT OK.....		
20	DOOR BARS/BRACE BARS OK.....		
21	ROLL CAGE NOT MEDIUM FOR WATER /ELECTRICS.....		
22	ROLL CAGE NASA FULLY WELDED.....		
23	ROLL CAGE FEET / F Frm PLATED.....		
24	NO FRONT PROTECTION.....		
25	FRONT BUMPERS + SUP'T BAR OK.....		
26	REAR BUMPERS / PROTECTION OK.....		
27	BATTERY CUT OFF SWITCH WORKING.....		
28	BATTERY BOX (ALL BATTERIES) OK.....		
29	BOX NOT OVERSIZE.....		
30	FUEL TANK 2 GALL MAX.....		
31	TAP IF FITTED INTEGRAL .....		
32	VENT PIPE TO BELOW FLOOR.....		
33	FIRE HOLE IF ENCLOSED.....		
34	NO FUEL/OIL/WATER LEAKS.....		
35	SECONDARY FASTENINGS OK.....		
36	WHEELS & TYRES COVERED 2"(50mm).....		
37	WHEEL STUDS FULL NUT THREAD.....		
38	WHEELS - CENTRE NOT CRACKED + RIM OK - NO DAMAGE.....		
39	WHEEL SPACERS ONE PIECE SOLID.....		
40	TYRES Option 'A' or 'B' only.....		
41	TYRES - NO BULGES/CUTS.....		
42	BALLAST TYPE OK.....		
43	NO SHARP PROJECTIONS.....		
44	ENGINE /GEARBOX IN ORIG COMP'T.....		
45	NO TRACTION CONTROL.....		

No.	DRIVERS COMPARTMENT	P	F
46	CRASH HELM'T BS NUMBERS.....		
47	CRASH HELM'T NOT PAINTED, STICKERED, DAMAGED.....		
48	ROLL CAGE 3" (75mm) ABOVE HELMET.....		
49	SAFETY HARNESS MIN 5 PT FIX.....		
50	NOT CUT/DAMAGED,BUCKLE OK.....		
51	HEAD RESTRAINT.....		
52	ARM RESTRAINT SYSTEM OK.....		
53	SEAT CORRECT.....		
54	SEAT SUPPORT+MOUNTINGS.....		
55	FIRE EXTINGUISHER CORRECT.....		
56	FIXED & WITHIN DRIVER REACH.....		
57	IGN SWITCH WITHIN DRIVER REACH.....		
58	ORIGINAL or STEEL FRONT BULKHEAD COMPLETE.....		
59	NO HOLES.....		
60	ORIG or STEEL FLOOR TO REAR ROLL CAGE FEET.....		
61	FLOOR FRAME OK.....		
62	LOWER X MEMBER 38mm X 38mm.....		
63	UPPER X BRACE 1" X 1".....		
64	END PLATES 3" X 3" INSIDE.....		
65	FWD - UPPER BULKHEAD/ FULL FIRE SHIELD.....		
66	RWD - ORIGINAL or STEEL LOWER FRONT BULKHEAD.....		
67	RWD - REAR BULKHEAD / FIRE SHIELD OK.....		
68	FUEL/OIL TANK SHIELDED.....		
69	FUEL/OIL/WATER PIPES COVERED.....		
70	EXHAUST TO REAR, EXIT OK .....		
71	EXHAUST SHIELDED.....		
72	FLYWHEEL SHIELD/PROT'N.....		
73	<b>ENGINE: TYPE OK</b>		
74	LOCATION OK FOR B'SHELL.....		
75	NO TURBO / SUPERCHARGER.....		
76	BONNET/ENGINE COVER ST'D		
77	BULGE/AIR BOX OK.....		
78	NO BULKHEAD MODIFICATION.....		
79	CARB RETURN SPRING.....		
80	PROV FOR ENGINE SEALING.....		
81	ENGINE CAPACITY LABEL.....		
82	ENGINE/G'BOX CRADLE OK.....		
	<b>CYLINDER HEAD:</b>		
83	ORIGINAL MATERIAL.....		
84	NO OF PORTS AS ORIGINAL.....		
85	POSITION OF PORTS IN HEAD FACE AS ORIGINAL.....		

CAR NO ..... N.A.S.A. LEAGUE .....

PASS..... FAIL..... LEAGUE CHIEF SCRUTINEER.....

FORM TO BE RETAINED BY COMPETITOR AND PRESENTED AT NAC

NASA - NATIONAL CHAMPIONSHIPS -- SCRUTINEERING PRE-CHECK LIST - 2013

**CLASS:** 5

DRIVER NAME..... LICENCE No.....

VEHICLE NUMBER..... DATE: .....

**\* CHECK LICENCE AND RULE BOOK FOR PREVIOUSLY LISTED FAULTS / COMMENTS \***

<b>NOISE TEST</b> MAX = 102 Db (A)	<b>PASS</b>	<b>COMMENTS</b>
NOISE READING _____ Db (A) @ _____ REVS / MIN		

<b>GENERAL INSPECTION</b> AS LISTED ON INSPECTION SCHEDULE ON NEXT PAGE	<b>PASS</b>	<b>COMMENTS</b>
<b>ITEMS</b>		

<b>NOISE TEST &amp; GENERAL INSPECTION</b> <b>ITEMS</b>	<b>FAIL</b>	<b>COMMENTS</b>

I certify that I have examined the above vehicle and have issued a **PASS / FAIL** as noted above.

LEAGUE CHIEF SCRUTINEER \_\_\_\_\_ Tel: \_\_\_\_\_

I certify that the above scrutineer has examined the above vehicle and issued a **PASS / FAIL** as noted above.

LEAGUE CHAIR \_\_\_\_\_ Tel: \_\_\_\_\_

For "PASS" THE FORM and INSPECTION SCHEDULE TO BE RETAINED BY COMPETITOR AND HANDED IN TO BAY 2 CLASS SCRUTINEER AT NAC  
If not presented then vehicle will be completely re-scrutineered at NAC.

The vehicle must be subject to the BAY 1 safety check at the NAC before proceeding to BAY 2.

For "FAIL" FORM TO BE RETAINED BY COMPETITOR UNTIL VEHICLE FAULTS HAVE BEEN REMEDIED AND VEHICLE RE-SCRUTINEERED AND A "PASS" ISSUED.

**NOTES**

It is the competitor's responsibility to ensure that the vehicle concerned complies with the NASA vehicle construction regulations. The original checked vehicle cannot be substituted by the use of another vehicle, unless authorised by the League Chair concerned. The substitute vehicle must be inspected and checked for compliance and separately certified.

It is the League Chief Scrutineer's responsibility to ensure that the items listed have been checked for compliance with the NASA vehicle construction regulations in accordance with the NASA Scrutineering procedures.

It is the League Chair's responsibility to ensure that the items listed have been checked for compliance with the NASA vehicle construction regulations in accordance with the NASA Scrutineering procedures.

Random checks will be made at National Autograss Championship (NAC) to check validity of inspection schedule. Possession of form does not exempt vehicle from further scrutineering inspection.

Where the certification of compliance with the construction rules is found to be false and or an unauthorised vehicle substituted the competitor and/or driver of the vehicle concerned shall be disqualified and will be reported for disciplinary action. The Scrutineer and League Chair will also be reported.

CLASS 5 NASA - NATIONAL CHAMPIONSHIPS -- SCRUTINEERING PRE-CHECK LIST - 2013

\* CHECK LICENCE AND RULE BOOK FOR PREVIOUSLY LISTED FAULTS / COMMENTS \*

No.	GENERAL			No.	DRIVERS COMPARTMENT		
		P	F			P	F
1	NOISE + BRAKE TEST PASS STICKER.....			46	CRASH HELM'T BS NUMBERS.....		
2	IDENTIFICATION OK.....			47	CRASH HELM'T NOT PAINTED, STICKERED, DAMAGED.....		
3	CLARITY OF NUMBERS/LETTERS.....			48	ROLL CAGE 3" (75mm) ABOVE HELMET.....		
4	BLACK ON WHITE PANEL / UPRIGHT.....			49	SAFETY HARNESS MIN 5 PT FIX.....		
5	BODYSHELL COMPLETE.....			50	NOT CUT/DAMAGED,BUCKLE OK.....		
6	TAILGATE/BOOTLID,VALANCE, WINGS.....			51	HEAD RESTRAINT .....		
7	ORIGINAL ENGINE COVER/BONNET.....			52	ARM RESTRAINT SYSTEM OK .....		
8	STD REPLACEMENT PANELS.....			53	SEAT CORRECT.....		
9	CORRECT SKINNING .....			54	SEAT SUPPORT+MOUNTINGS.....		
10	NO REINFORCEMENT.....			55	FIRE EXTINGUISHER CORRECT.....		
11	FLICH PANEL REMOVED 1" BOX.....			56	FIXED & WITHIN DRIVER REACH.....		
12	AIR COOLING HOLES OK.....			57	IGN SWITCH WITHIN DRIVER REACH.....		
13	ALL DOORS WELDED.....			58	ORIGINAL or STEEL STEEL FRONT BULKHEAD COMPLETE.....		
14	DRIVER'S DOOR MNF'RD HEIGHT.....			59	NO HOLES.....		
15	PASS'NGR DOORS 3/4 MNF'R HGHT.....			60	ORIG or STEEL FLOOR TO REAR ROLL CAGE FEET.....		
16	FULL HEIGHT IF CENTRAL SEAT.....			61	FLOOR FRAME OK.....		
17	TOWING EYE 50mm @ FRONT + REAR.....			62	LOWER X MEMBER 38mm X 38mm.....		
18	SCREEN MESH 1" * 1"(25mm * 25mm).....			63	UPPER X BRACE 1" X 1".....		
19	PERSPEX OUTSIDE FRONT SCREEN ONLY.....			64	END PLATES 3" X 3" INSIDE.....		
20	ROLL CAGE DESIGN + FIT OK.....			65	FWD FRONT ENGINE: UPPER BULKHEAD/FULL FIRE SHIELD.....		
21	DOOR BARS/BRACE BARS OK.....			66	FWD - SLIGHT LOCAL MODS TO		
22	ROLL CAGE NOT MEDIUM FOR WATER /ELECTRICS.....			67	LOWER BULKHEAD.....		
23	ROLL CAGE NASA FULLY WELDED.....			68	RWD FRONT ENGINE:- SLIGHT LOCAL MODS TO FRONT B'KHEAD..		
24	ROLL CAGE FEET / F Frm PLATED.....			69	RWD MID/REAR ENGINE: SAFETY/FIRE SHIELD OK.....		
25	NO FRONT PROTECTION.....			70	FUEL/OIL TANK SHIELDED.....		
26	FRONT BUMPERS + SUP'T BAR OK.....			71	FUEL/OIL/WATER PIPES COVERED.....		
27	REAR BUMPERS / PROTECTION OK.....			72	EXHAUST TO REAR, EXIT OK .....		
28	BATTERY CUT OFF SWITCH WORKING.....			73	EXHAUST SHIELDED.....		
29	BATTERY BOX (ALL BATTERIES).....			74	FLYWHEEL SHIELD/PROT'N.....		
30	BOX NOT OVERSIZE.....			75	ENGINE: 2 VALVE/CYL.....		
31	FUEL TANK 2 GALL MAX.....			76	ENGINE NOT M'BIKE DERIVED.....		
32	TAP IF FITTED INTEGRAL .....			77	BONNET/ENGINE COVER ST'D BULGE/AIR BOX OK.....		
33	VENT PIPE TO BELOW FLOOR.....			78	PROV FOR ENGINE SEALING.....		
34	FIRE HOLE IF ENCLOSED.....			79	ENGINE CAPACITY LABEL.....		
35	NO FUEL/OIL/WATER LEAKS.....			80	NO TURBO/SUPERCHARGER.....		
36	SECONDARY FASTENINGS OK.....			81	CARB / Flnj RETURN SPRING.....		
37	WHEELS & TYRES COVERED 2"(50mm).....			82	ENGINE/G'BOX CRADLE OK.....		
38	WHEEL STUDS FULL NUT THREAD.....						
39	WHEELS - CENTRE NOT CRACKED + RIM OK - NO DAMAGE.....						
40	WHEEL SPACERS ONE PIECE SOLID.....						
41	TYRES Option 'A' or 'B' only.....						
42	TYRES - NO BULGES/CUTS.....						
43	NO SHARP PROJECTIONS.....						
44	BALLAST TYPE OK.....						
45	NO TRACTION CONTROL.....						

CAR NO ..... N.A.S.A. LEAGUE .....

PASS..... FAIL..... LEAGUE CHIEF SCRUTINEER.....

FORM TO BE RETAINED BY COMPETITOR AND PRESENTED AT NAC

NASA - NATIONAL CHAMPIONSHIPS -- SCRUTINEERING PRE-CHECK LIST - 2013

CLASS: 6

DRIVER NAME..... LICENCE No.....

VEHICLE NUMBER..... DATE: .....

**\* CHECK LICENCE AND RULE BOOK FOR PREVIOUSLY LISTED FAULTS / COMMENTS \***

<b>NOISE TEST</b> MAX = 102 Db (A)	<b>PASS</b>	<b>COMMENTS</b>
NOISE READING _____ Db (A) @ _____ REVS / MIN		

<b>GENERAL INSPECTION ITEMS</b> AS LISTED ON INSPECTION SCHEDULE ON NEXT PAGE	<b>PASS</b>	<b>COMMENTS</b>

<b>NOISE TEST &amp; GENERAL INSPECTION ITEMS</b>	<b>FAIL</b>	<b>COMMENTS</b>

I certify that I have examined the above vehicle and have issued a PASS / FAIL as noted above.

LEAGUE CHIEF SCRUTINEER \_\_\_\_\_ Tel: \_\_\_\_\_

I certify that the above scrutineer has examined the above vehicle and issued a PASS / FAIL as noted above.

LEAGUE CHAIR \_\_\_\_\_ Tel: \_\_\_\_\_

For "PASS" THE FORM and INSPECTION SCHEDULE TO BE RETAINED BY COMPETITOR AND HANDED IN TO BAY 2 CLASS SCRUTINEER AT NAC  
If not presented then vehicle will be completely re-scrutineered at NAC.

The vehicle must be subject to the BAY 1 safety check at the NAC before proceeding to BAY 2.

For "FAIL" FORM TO BE RETAINED BY COMPETITOR UNTIL VEHICLE FAULTS HAVE BEEN REMEDIED AND VEHICLE RE-SCRUTINEERED AND A "PASS" ISSUED.

**NOTES**

It is the competitor's responsibility to ensure that the vehicle concerned complies with the NASA vehicle construction regulations. The original checked vehicle cannot be substituted by the use of another vehicle, unless authorised by the League Chair concerned. The substitute vehicle must be inspected and checked for compliance and seperately certified.

It is the League Chief Scrutineer's responsibility to ensure that the items listed have been checked for compliance with the NASA vehicle construction regulations in accordance with the NASA Scrutineering procedures.

It is the League Chair's responsibility to ensure that the items listed have been checked for compliance with the NASA vehicle construction regulations in accordance with the NASA Scrutineering procedures.

Random checks will be made at National Autograss Championship (NAC) to check validity of inspection schedule. Possession of form does not exempt vehicle from further scrutineering inspection.

Where the certification of compliance with the construction rules is found to be false and or an unauthorised vehicle substituted the competitor and/or driver of the vehicle concerned shall be disqualified and will be reported for disciplinary action. The Scrutineer and League Chair will also be reported.

**CLASS 6 NASA - NATIONAL CHAMPIONSHIPS -- SCRUTINEERING PRE-CHECK LIST - 2013**

**\* CHECK LICENCE AND RULE BOOK FOR PREVIOUSLY LISTED FAULTS / COMMENTS \***

No.	<u>GENERAL</u>	P	F
1	NOISE + BRAKE TEST PASS STICKER.....		
2	IDENTIFICATION OK.....		
3	CLARITY OF NUMBERS/LETTERS.....		
4	BLACK ON WHITE PANEL / UPRIGHT.....		
5	BODYSHELL COMPLETE.....		
6	TAILGATE/BOOTLID,VALANCE, WINGS.....		
7	ORIGINAL ENGINE COVER/BONNET.....		
8	STD REPLACEMENT PANELS.....		
9	CORRECT SKINNING.....		
10	NO REINFORCEMENT.....		
11	FLICH PANEL REMOVED 1" BOX.....		
12	AIR COOLING HOLES OK.....		
13	ALL DOORS WELDED.....		
14	DRIVER'S DOOR MNF'RD HEIGHT.....		
15	PASS'NGR DOORS 3/4 MNF'R HGHT.....		
16	TOWING EYE 50mm @ FRONT + REAR.....		
17	SCREEN MESH 1" * 1"(25mm * 25mm).....		
18	PERSPEX OUTSIDE FRONT SCREEN ONLY.....		
19	ROLL CAGE DESIGN + FIT OK.....		
20	DOOR BARS/BRACE BARS OK.....		
21	ROLL CAGE NOT MEDIUM FOR WATER /ELECTRICS.....		
22	ROLL CAGE NASA FULLY WELDED.....		
23	ROLL CAGE FEET / F Frm PLATED.....		
24	NO FRONT PROTECTION.....		
25	FRONT BUMPERS + SUP'T BAR OK.....		
26	REAR BUMPERS / PROTECTION OK.....		
27	BATTERY CUT OFF SWITCH WORKING.....		
28	BATTERY BOX (ALL BATTERIES) OK.....		
29	BOX NOT OVERSIZE.....		
30	FUEL TANK 2 GALL MAX.....		
31	TAP IF FITTED INTEGRAL.....		
32	VENT PIPE TO BELOW FLOOR.....		
33	FIRE HOLE IF ENCLOSED.....		
34	NO FUEL/OIL/WATER LEAKS.....		
35	SECONDARY FASTENINGS OK.....		
36	WHEELS & TYRES COVERED 2"(50mm).....		
37	WHEELS - CENTRE NOT CRACKED + RIM OK - NO DAMAGE.....		
38	WHEEL SPACERS ONE PIECE SOLID.....		
39	TYRES Option 'A' or 'B' only.....		
40	TYRES - NO BULGES/CUTS.....		
41	NO SHARP PROJECTIONS.....		
42	BALLAST TYPE OK.....		
43	NO TRACTION CONTROL.....		

No.	<u>DRIVERS COMPARTMENT</u>	P	F
44	CRASH HELM'T BS NUMB'RS.....		
45	CRASH HELM'T NOT PAINTED, STICKERED, DAMAGED.....		
46	ROLL CAGE 3" (75mm) ABOVE HELMET.....		
47	SAFETY HARNESS MIN 5 PT FIX.....		
48	NOT CUT/DAMAGED,BUCKLE OK.....		
49	HEAD RESTRAINT.....		
50	ARM RESTRAINT SYSTEM OK.....		
51	SEAT CORRECT.....		
52	SEAT SUPPORT+MOUNTINGS.....		
53	FIRE EXTINGUISHER CORRECT.....		
54	FIXED & WITHIN DRIVER REACH.....		
55	IGN SWITCH WITHIN DRIVER REACH.....		
56	ORIGINAL or STEEL FRONT BULKHEAD COMPLETE.....		
57	NO HOLES.....		
58	ORIG or STEEL FLOOR TO REAR ROLL CAGE FEET.....		
59	FLOOR FRAME OK.....		
60	LOWER X MEMBER 38mm X 38mm.....		
61	UPPER X MEMBER 1" X 1".....		
62	END PLATES 3" X 3" INSIDE.....		
63	FRONT ENGINE: UPPER BULKHEAD/FULL FIRE SHIELD.....		
64	SLIGHT LOCAL MODS TO LOWER BULKHEAD.....		
65	FUEL/OIL TANK SHIELDED.....		
66	FUEL/OIL/WATER PIPES COVERED.....		
67	EXHAUST TO REAR, EXIT OK.....		
68	EXHAUST SHIELDED.....		
69	FLYWHEEL SHIELD/PROT'N.....		
70	ENGINE + FRONT SUSPENSION FRAME + CRADLE OK.....		
71	<b>ENGINE: TYPE OK</b>		
72	NOT M'BIKE DERIVED.....		
73	FULL FIRE SHIELD.....		
74	BONNET/ENGINE COVER ST'D.....		
75	BULGE/AIR BOX OK.....		
76	CARB / Flnj RETURN SPRING.....		

CAR NO ..... N.A.S.A. LEAGUE .....

PASS..... FAIL..... LEAGUE CHIEF SCRUTINEER.....

FORM TO BE RETAINED BY COMPETITOR AND PRESENTED AT NAC

NASA - NATIONAL CHAMPIONSHIPS -- SCRUTINEERING PRE-CHECK LIST - 2013

**CLASS:** 7

DRIVER NAME..... LICENCE No.....

VEHICLE NUMBER..... DATE: .....

**\* CHECK LICENCE AND RULE BOOK FOR PREVIOUSLY LISTED FAULTS / COMMENTS \***

<b>NOISE TEST</b> MAX = 102 Db (A)	<b>PASS</b>	<b>COMMENTS</b>
NOISE READING _____ Db (A) @ _____ REVS / MIN		

<b>GENERAL INSPECTION</b> <b>ITEMS</b> AS LISTED ON INSPECTION SCHEDULE ON NEXT PAGE	<b>PASS</b>	<b>COMMENTS</b>

<b>NOISE TEST &amp; GENERAL INSPECTION</b> <b>ITEMS</b>	<b>FAIL</b>	<b>COMMENTS</b>

I certify that I have examined the above vehicle and have issued a **PASS / FAIL** as noted above.

LEAGUE CHIEF SCRUTINEER \_\_\_\_\_ Tel: \_\_\_\_\_

I certify that the above scrutineer has examined the above vehicle and issued a **PASS / FAIL** as noted above.

LEAGUE CHAIR \_\_\_\_\_ Tel: \_\_\_\_\_

For "PASS" THE FORM and INSPECTION SCHEDULE TO BE RETAINED BY COMPETITOR AND HANDED IN TO BAY 2 CLASS SCRUTINEER AT NAC  
If not presented then vehicle will be completely re-scrutineered at NAC.

The vehicle must be subject to the BAY 1 safety check at the NAC before proceeding to BAY 2.

For "FAIL" FORM TO BE RETAINED BY COMPETITOR UNTIL VEHICLE FAULTS HAVE BEEN REMEDIED AND VEHICLE RE-SCRUTINEERED AND A "PASS" ISSUED.

**NOTES**

It is the competitor's responsibility to ensure that the vehicle concerned complies with the NASA vehicle construction regulations. The original checked vehicle cannot be substituted by the use of another vehicle, unless authorised by the League Chair concerned. The substitute vehicle must be inspected and checked for compliance and seperately certified.

It is the League Chief Scrutineer's responsibility to ensure that the items listed have been checked for compliance with the NASA vehicle construction regulations in accordance with the NASA Scrutineering procedures.

It is the League Chair's responsibility to ensure that the items listed have been checked for compliance with the NASA vehicle construction regulations in accordance with the NASA Scrutineering procedures.

Random checks will be made at National Autograss Championship (NAC) to check validity of inspection schedule. Possession of form does not exempt vehicle from further scrutineering inspection.

Where the certification of compliance with the construction rules is found to be false and or an unauthorised vehicle substituted the competitor and/or driver of the vehicle concerned shall be disqualified and will be reported for disciplinary action. The Scrutineer and League Chair will also be reported.

CLASS 7 NASA - NATIONAL CHAMPIONSHIPS -- SCRUTINEERING PRE-CHECK LIST - 2013

\* CHECK LICENCE AND RULE BOOK FOR PREVIOUSLY LISTED FAULTS / COMMENTS \*

No.	GENERAL	P	F	No.	DRIVERS COMPARTMENT	P	F
1	NOISE + BRAKE TEST PASS STICKER.....			46	CRASH HELM'T BS NUMBERS.....		
2	IDENTIFICATION OK.....			47	CRASH HELM'T NOT PAINTED, STICKERED, DAMAGED.....		
3	CLARITY OF NUMBERS/LETTERS.....			48	ROLL CAGE 3" (75mm) ABOVE HELMET.....		
4	BLACK ON WHITE PANEL / UPRIGHT.....			49	SAFETY HARNESS MIN 5 PT FIX.....		
5	BODYSHELL COMPLETE.....			50	NOT CUT/DAMAGED,BUCKLE OK.....		
6	TAILGATE/BOOTLID,VALANCE, WINGS.....			51	HEAD RESTRAINT .....		
7	ORIGINAL ENGINE COVER/BONNET.....			52	ARM RESTRAINT SYSTEM OK .....		
8	STD REPLACEMENT PANELS.....			53	SEAT CORRECT.....		
9	CORRECT SKINNING .....			54	SEAT SUPPORT+MOUNTINGS.....		
10	NO REINFORCEMENT.....			55	FIRE EXTINGUISHER CORRECT.....		
11	FLICH PANEL REMOVED 1" BOX.....			56	FIXED & WITHIN DRIVER REACH.....		
12	AIR COOLING HOLES OK.....			57	IGN SWITCH WITHIN DRIVER REACH.....		
13	ALL DOORS WELDED.....			58	ORIGINAL or STEEL FRONT BULKHEAD COMPLETE.....		
14	DRIVER'S DOOR MNF'RD HEIGHT.....			59	NO HOLES.....		
15	PASS'NGR DOORS 3/4 MNF'R HGHT.....			60	ORIG or STEEL FLOOR TO REAR ROLL CAGE FEET.....		
16	TOWING EYE 50mm @ FRONT + REAR.....			61	FLOOR FRAME OK.....		
17	SCREEN MESH 1" * 1"(25mm * 25mm).....			62	LOWER X MEMBER 38mm X 38mm.....		
18	PERSPEX OUTSIDE FRONT SCREEN ONLY.....			63	UPPER X MEMBER 1" X 1".....		
19	ROLL CAGE DESIGN + FIT OK.....			64	END PLATES 3" X 3" INSIDE.....		
20	DOOR BARS/BRACE BARS OK.....			65	FUEL/OIL TANK SHIELDED.....		
21	ROLL CAGE NOT MEDIUM FOR WATER /ELECTRICS.....			66	FUEL/OIL/WATER PIPES COVERED.....		
22	ROLL CAGE NASA FULLY WELDED.....			67	EXHAUST TO REAR, EXIT OK .....		
23	ROLL CAGE FEET / F Frm PLATED.....			68	EXHAUST SHIELDED.....		
24	NO FRONT PROTECTION.....			69	<b>ENGINE: SINGLE/TWIN</b>		
25	FRONT BUMPERS + SUP'T BAR OK.....			70	FRONT ENGINE: NOT AS CL3 or 5 CLASS cc N. ASP MIN: 1421cc FORCED IND MINcc:FREE M'BIKE MINcc:FREE		
26	REAR BUMPERS / PROTECTION OK.....			71	SLIGHT LOCAL MODS TO FRONT BULKHEAD.....		
27	BATTERY CUT OFF SWITCH WORKING.....			72	FULL SAFETY/FIRE SHIELD.....		
28	BATTERY BOX (ALL BATTERIES).....			73	FLYWHEEL SHIELD/PROT'N.....		
29	BOX NOT OVERSIZE.....			74	MID/REAR ENGINE: FULL SAFETY/FIRE SHIELD.....		
30	FUEL TANK 2 GALL MAX.....			75	BONNET/ENGINE COVER ST'D BULGE/AIR BOX SIZE OK.....		
31	TAP IF FITTED INTEGRAL .....			76	CARB / FI RETURN SPRING.....		
32	VENT PIPE TO BELOW FLOOR.....			77	CARB / Flnj PROTECTION BAR.....		
33	FIRE HOLE IF ENCLOSED.....			78	ENGINE/G'BOX CRADLE OK.....		
34	NO FUEL/OIL/WATER LEAKS.....						
35	SECONDARY FASTENINGS OK.....						
36	WHEELS & TYRES COVERED 2"(50mm).....						
37	WHEEL STUDS FULL NUT THREAD.....						
38	WHEELS - CENTRE NOT CRACKED.....						
39	WHEELS - CENTRE NOT CRACKED + RIM OK - NO DAMAGE.....						
40	WHEEL SPACERS ONE PIECE SOLID.....						
41	TYRES Option 'A' or 'B' only.....						
42	TYRES - NO BULGES/CUTS.....						
43	NO SHARP PROJECTIONS.....						
44	BALLAST TYPE OK.....						
45	NO TRACTION CONTROL.....						

CAR NO ..... N.A.S.A. LEAGUE .....

PASS..... FAIL..... LEAGUE CHIEF SCRUTINEER.....

FORM TO BE RETAINED BY COMPETITOR AND PRESENTED AT NAC

**NASA - NATIONAL CHAMPIONSHIPS -- SCRUTINEERING PRE-CHECK LIST - 2012/13**

**CLASS:** **Junior Special**

DRIVER NAME..... LICENCE No.....

VEHICLE NUMBER..... DATE: .....

**\* CHECK LICENCE AND RULE BOOK FOR PREVIOUSLY LISTED FAULTS / COMMENTS \***

<b>NOISE TEST</b>	<b>PASS</b>	<b>COMMENTS</b>
MAX = 102 Db (A)		
NOISE READING _____ Db (A) @ _____ REVS / MIN		

<b>GENERAL INSPECTION</b>	<b>PASS</b>	<b>COMMENTS</b>
AS LISTED ON INSPECTION SCHEDULE ON NEXT PAGE		

<b>NOISE TEST &amp; GENERAL INSPECTION</b>	<b>FAIL</b>	<b>COMMENTS</b>
ITEMS		

I certify that I have examined the above vehicle and have issued a PASS / FAIL as noted above.

LEAGUE CHIEF SCRUTINEER \_\_\_\_\_ Tel: \_\_\_\_\_

I certify that the above scrutineer has examined the above vehicle and issued a PASS / FAIL as noted above.

LEAGUE CHAIR \_\_\_\_\_ Tel: \_\_\_\_\_

For "PASS" THE FORM and INSPECTION SCHEDULE TO BE RETAINED BY COMPETITOR AND HANDED IN TO BAY 2 CLASS SCRUTINEER AT NAC  
If not presented then vehicle will be completely re-scrutineered at NAC.

The vehicle must be subject to the BAY 1 safety check at the NAC before proceeding to BAY 2.

For "FAIL" FORM TO BE RETAINED BY COMPETITOR UNTIL VEHICLE FAULTS HAVE BEEN REMEDIED AND VEHICLE RE-SCRUTINEERED AND A "PASS" ISSUED.

**NOTES**

It is the competitor's responsibility to ensure that the vehicle concerned complies with the NASA vehicle construction regulations. The original checked vehicle cannot be substituted by the use of another vehicle, unless authorised by the League Chair concerned. The substitute vehicle must be inspected and checked for compliance and separately certified.

It is the League Chief Scrutineer's responsibility to ensure that the items listed have been checked for compliance with the NASA vehicle construction regulations in accordance with the NASA Scrutineering procedures.

It is the League Chair's responsibility to ensure that the items listed have been checked for compliance with the NASA vehicle construction regulations in accordance with the NASA Scrutineering procedures.

Random checks will be made at National Autograss Championship (NAC) to check validity of inspection schedule. Possession of form does not exempt vehicle from further scrutineering inspection.

Where the certification of compliance with the construction rules is found to be false and or an unauthorised vehicle substituted the competitor and/or driver of the vehicle concerned shall be disqualified and will be reported for disciplinary action. The Scrutineer and League Chair will also be reported.



JUNIOR SPECIAL **NASA - NATIONAL CHAMPIONSHIPS -- SCRUTINEERING PRE-CHECK LIST - 2013**

**\* CHECK LICENCE AND RULE BOOK FOR PREVIOUSLY LISTED FAULTS / COMMENTS \***

No.	<b>GENERAL</b>	P	F	No.	<b>DRIVERS COMPARTMENT</b>	P	F
1	NOISE + BRAKE TEST PASS STICKER.....			47	CRASH HELM'T BS NUMB'RS.....		
2	IDENTIFICATION OK.....			48	CRASH HELM'T NOT PAINTED, STICKERED, DAMAGED.....		
3	CLARITY OF NUMBERS/LETTERS.....			49	ROLL CAGE 3" (75mm) ABOVE HELMET.....		
4	BLACK ON WHITE PANEL / UPRIGHT.....			50	SAFETY HARNESS MIN 5 PT FIX.....		
	<b>CHASSIS CONSTRUCTION: -</b>			51	NOT CUT/DAMAGED,BUCKLE OK		
5	STEEL SPACEFRAME.....			52	HEAD RESTRAINT.....		
6	WITHSTAND COLLISION/ROLL ETC.....			53	ARM RESTRAINT SYSTEM OK.....		
7	ROLL CAGE + BRACE BARS OK.....			54	SEAT CORRECT.....		
8	ROLL CAGE NOT MEDIUM FOR WATER / ELECTRICS.....			55	SEAT SUPPORT+MOUNTINGS.....		
9	ROLL CAGE FULLY WELDED.....			56	FIRE EXTINGUISHER CORRECT.....		
10	ROOF WIDTH ABOVE 20"(510mm).....			57	FIXED & WITHIN DRIVER REACH.....		
11	ROOF HEIGHT ABOVE 42"(1066mm).....			58	IGN SWITCH WITHIN DRIVER REACH.....		
12	REAR BRACE BAR 18"(457mm).....			59	STEEL FLOOR 2mm.....		
13	DIMENSION 'W' BELOW 2"(50mm).....			60	NO HOLES IN FLOOR.....		
14	FRONT BRACE BAR 4"(100mm).....			61	AIR SCOOP 3"(75mm) * 18"(457mm).....		
15	SIDE PANEL 6"(150mm) ABOVE ELBOWS...			62	BRAKE PIPES SHIELDED		
16	DRIVER COMPARTMENT WIDTH			63	<b>WEIGHT MIN 455Kg OK.....</b>		
17	(DIMENSION 'U') 24"(600mm) AT TOP.....			64	SUMP GUARD OK.....		
18	DRIVERS HIPS DISTANCE 'V' 50mm.....			65	NO BALLAST.....		
19	SIDE PODS/BARS.....			66	LIFTING EYE OK.....		
20	TOWING EYE 50mm @ FRONT + REAR.....				<b>REAR OF ROLL CAGE</b>		
21	FRONT FLAT+SIZE 8"(203mm) * 24"(600mm)...			67	BATTERY.....		
22	WHEEL CENTRE TO FRONT 24"(600mm).....			68	FUEL TANK.....		
23	DRIVERS FEET TO FRONT 9"(230mm).....			69	ENGINE.....		
24	NO FRONT PROTECTION.....			70	GEARBOX.....		
25	REAR PROTECTION OK.....			71	EXHAUST.....		
26	FUEL/OIL TANK PROTECTION.....			72	RADIATOR OK.....		
27	BATTERY BOX (ALL BATTERIES).....			73	RADIATOR STD TYPE.....		
28	BATTERY CUT OFF SWITCH WORKING.....			74	REAR SUSP MTGS OK.....		
29	SCREEN MESH 1" * 1"(25mm * 25mm).....			75	FULL SAFETY/FIRE SHIELD.....		
30	PERSPEX OUTSIDE FRONT SCREEN ONLY.....			76	FLYWHEEL SHIELD/PROT'N OK.....		
31	RADIATOR HEIGHT + FIT WITHIN AREA.....			77	<b>ENGINE: SINGLE VAUXHALL</b> CLASS cc : 1196cc		
32	RADIATOR PROTECTION.....			78	CARB/FInj STD.....		
33	FUEL TANK & INTEGRAL TAP.....			79	CARB RETURN SPRING.....		
34	10 LITRE CAPACITY LIMIT.....			80	AIR INTAKE 55mm.....		
35	VENT PIPE TO BELOW FLOOR.....			81	1 ECU.....		
36	FIRE HOLE IF TANK ENCLOSED.....			82	REV LIMIT 6250.....		
37	NO FUEL/OIL/WATER LEAKS.....			83	PROV FOR ENGINE SEALING.....		
38	WHEEL STUDS FULL NUT THREAD.....			84	STD EXHAUST MANIFOLD OK.....		
39	WHEELS - CENTRE NOT CRACKED..... RIM OK - NO DAMAGE.....			85	EXHAUST WITHIN SET AREA.....		
40	WHEEL SPACERS ONE PIECE SOLID.....			86	SILENCER OK.....		
41	TYRES Option 'A' or 'B' only.....			87	OUTLET HORIZ / 30 Deg.....		
42	TYRES - NO BULGES/CUTS.....				<b>REAR SUSPENSION</b>		
43	SIZE Min 145x13 - Max 185x13 Or 185x14.....			88	STD VAUXHALL TIE BARS.....		
44	SECONDARY FASTENINGS OK.....			89	STD VAUXHALL STRUTS ONLY.....		
45	NO SHARP PROJECTIONS.....			90	REAR BRAKE DISC SIZE OK.....		
46	NO TRACTION CONTROL.....			91	H'BRAKE OK.....		
				92	DIFF TURNS FREE.....		

CAR NO ..... N.A.S.A. LEAGUE .....

PASS..... FAIL..... LEAGUE CHIEF SCRUTINEER.....

FORM TO BE RETAINED BY COMPETITOR AND PRESENTED AT NAC

NASA - NATIONAL CHAMPIONSHIPS -- SCRUTINEERING PRE-CHECK LIST - 2013

**CLASS:** 8

DRIVER NAME..... LICENCE No.....

VEHICLE NUMBER..... DATE: .....

**\* CHECK LICENCE AND RULE BOOK FOR PREVIOUSLY LISTED FAULTS / COMMENTS \***

<b>NOISE TEST</b> MAX = 102 Db (A)	<b>PASS</b>	<b>COMMENTS</b>
NOISE READING _____ Db (A) @ _____ REVS / MIN		

<b>GENERAL INSPECTION</b> AS LISTED ON INSPECTION SCHEDULE ON NEXT PAGE	<b>PASS</b>	<b>COMMENTS</b>
<b>ITEMS</b>		

<b>NOISE TEST &amp; GENERAL INSPECTION</b> <b>ITEMS</b>	<b>FAIL</b>	<b>COMMENTS</b>

I certify that I have examined the above vehicle and have issued a **PASS / FAIL** as noted above.

LEAGUE CHIEF SCRUTINEER \_\_\_\_\_ Tel: \_\_\_\_\_

I certify that the above scrutineer has examined the above vehicle and issued a **PASS / FAIL** as noted above.

LEAGUE CHAIR \_\_\_\_\_ Tel: \_\_\_\_\_

For "PASS" THE FORM and INSPECTION SCHEDULE TO BE RETAINED BY COMPETITOR AND HANDED IN TO BAY 2 CLASS SCRUTINEER AT NAC  
If not presented then vehicle will be completely re-scrutineered at NAC.

The vehicle must be subject to the BAY 1 safety check at the NAC before proceeding to BAY 2.

For "FAIL" FORM TO BE RETAINED BY COMPETITOR UNTIL VEHICLE FAULTS HAVE BEEN REMEDIED AND VEHICLE RE-SCRUTINEERED AND A "PASS" ISSUED.

**NOTES**

It is the competitor's responsibility to ensure that the vehicle concerned complies with the NASA vehicle construction regulations. The original checked vehicle cannot be substituted by the use of another vehicle, unless authorised by the League Chair concerned. The substitute vehicle must be inspected and checked for compliance and seperately certified.

It is the League Chief Scrutineer's responsibility to ensure that the items listed have been checked for compliance with the NASA vehicle construction regulations in accordance with the NASA Scrutineering procedures.

It is the League Chair's responsibility to ensure that the items listed have been checked for compliance with the NASA vehicle construction regulations in accordance with the NASA Scrutineering procedures.

Random checks will be made at National Autograss Championship (NAC) to check validity of inspection schedule. Possession of form does not exempt vehicle from further scrutineering inspection.

Where the certification of compliance with the construction rules is found to be false and or an unauthorised vehicle substituted the competitor and/or driver of the vehicle concerned shall be disqualified and will be reported for disciplinary action. The Scrutineer and League Chair will also be reported.

**CLASS 8 NASA - NATIONAL CHAMPIONSHIPS -- SCRUTINEERING PRE-CHECK LIST - 2013**

**\* CHECK LICENCE AND RULE BOOK FOR PREVIOUSLY LISTED FAULTS / COMMENTS \***

No.	<b>GENERAL</b>		
		P	F
1	NOISE + BRAKE TEST PASS STICKER.....		
2	IDENTIFICATION OK.....		
3	CLARITY OF NUMBERS/LETTERS.....		
4	BLACK ON WHITE PANEL / UPRIGHT.....		
<b>CHASSIS CONSTRUCTION: -</b>			
5	STEEL SPACEFRAME.....		
6	WITHSTAND COLLISION/ROLL ETC.....		
7	ROLL CAGE + BRACE BARS OK.....		
8	ROLL CAGE NOT MEDIUM FOR WATER..... / ELECTRICS.....		
9	ROLL CAGE FULLY WELDED.....		
10	ROOF WIDTH ABOVE 20"(510mm).....		
11	ROOF HEIGHT ABOVE 42"(1066mm).....		
12	REAR BRACE BAR 18"(457mm).....		
13	DIMENSION 'W' BELOW 2"(50mm).....		
14	FRONT BRACE BAR 4"(100mm).....		
15	SIDE PANEL 6"(150mm) ABOVE ELBOWS....		
16	DRIVER COMPARTMENT WIDTH		
17	(DIMENSION 'U') 24"(600mm) AT TOP.....		
18	DRIVERS HIPS DISTANCE 'V' 50mm.....		
19	SIDE PODS/BARS.....		
20	TOWING EYE 50mm @ FRONT + REAR.....		
21	FRONT FLAT+SIZE 8"(203mm) * 24"(600mm)		
22	WHEEL CENTRE TO FRONT 24"(600mm).....		
23	DRIVERS FEET TO FRONT 9"(230mm).....		
24	NO FRONT PROTECTION.....		
25	REAR PROTECTION OK.....		
26	FUEL/OIL TANK PROTECTION.....		
27	BATTERY BOX (ALL BATTERIES) OK.....		
28	BATTERY CUT OFF SWITCH WORKING.....		
29	SCREEN MESH 1" * 1"(25mm * 25mm).....		
30	PERSPEX OUTSIDE FRONT SCREEN ONLY.....		
31	RADIATOR HEIGHT + FIT WITHIN AREA.....		
32	RADIATOR PROTECTION.....		
33	FUEL TANK & INTEGRAL TAP.....		
34	10 LITRE CAPACITY LIMIT.....		
35	VENT PIPE TO BELOW FLOOR.....		
36	FIRE HOLE IF TANK ENCLOSED.....		
37	NO FUEL/OIL/WATER LEAKS.....		
38	WHEEL STUDS FULL NUT THREAD.....		
39	WHEELS - CENTRE NOT CRACKED..... RIM OK - NO DAMAGE.....		
40	WHEEL SPACERS ONE PIECE SOLID.....		
41	TYRES Option 'A' or 'B' only.....		
42	TYRES - NO BULGES/CUTS.....		
43	SECONDARY FASTENINGS OK.....		
44	BALLAST OK.....		
45	NO SHARP PROJECTIONS.....		

No.	<b>DRIVERS COMPARTMENT</b>		
		P	F
46	CRASH HELM'T BS NUMB'RS.....		
47	CRASH HELM'T NOT PAINTED, STICKERED, DAMAGED.....		
48	ROLL CAGE 3" (75mm) ABOVE HELMET.....		
49	SAFETY HARNESS MIN 5 PT FIX.....		
50	NOT CUT/DAMAGED,BUCKLE OK		
51	HEAD RESTRAINT.....		
52	ARM RESTRAINT SYSTEM OK.....		
53	SEAT CORRECT.....		
54	SEAT SUPPORT+MOUNTINGS.....		
55	FIRE EXTINGUISHER CORRECT.....		
53	FIXED & WITHIN DRIVER REACH.....		
57	IGN SWITCH WITHIN DRIVER REACH.....		
58	STEEL FLOOR 2mm.....		
59	NO HOLES IN FLOOR.....		
60	FUEL/OIL/WATER PIPES COVERED.....		
61	FUEL TANK SHIELDED.....		
62	OIL/DRY SUMP TANK SHIELDED.....		
63	EXHAUST SHIELDED.....		
64	BRAKE PIPES SHIELDED		
65	AIR SCOOP 3"(75mm) * 18"(457mm).....		
<b>EXTERNALLY AT SIDE OF DRIVERS COMPARTMENT:</b>			
66	OIL/FUEL TANKS & BATTERIES ENCLOSED: MIN 20mm BOX / 25mm CIRC. STEEL.....		
<b>ENGINE:</b>			
67	CLASS cc LIMIT 1420cc Car Eng. 1350cc M'Bike Eng		
68	BORE/STROKE/cc LABEL TAG.....		
69	CARB / Flnj RETURN SPRING.....		
70	CARB / Flnj PROTECTION BAR.....		
71	PROV FOR ENGINE SEALING.....		
72	FULL SAFETY/FIRE SHIELD.....		
73	EXHAUST SYSTEM OK.....		
74	EXHAUST WITHIN SET AREA.....		
75	SILENCER OK.....		
76	OUTLET HORIZ / 30 Deg .....		
77	CHAIN GUARD.....		
78	ROTATING PULLEYS GUARD.....		
79	FLYWHEEL SHIELD OK.....		
80	NO TRACTION CONTROL.....		

CAR NO ..... N.A.S.A. LEAGUE .....

PASS..... FAIL..... LEAGUE CHIEF SCRUTINEER.....

FORM TO BE RETAINED BY COMPETITOR AND PRESENTED AT NAC

NASA - NATIONAL CHAMPIONSHIPS -- SCRUTINEERING PRE-CHECK LIST - 2013

**CLASS:** 9

DRIVER NAME..... LICENCE No.....

VEHICLE NUMBER..... DATE: .....

**\* CHECK LICENCE AND RULE BOOK FOR PREVIOUSLY LISTED FAULTS / COMMENTS \***

<b>NOISE TEST</b> MAX = 102 Db (A)	<b>PASS</b>	<b>COMMENTS</b>
NOISE READING _____ Db (A) @ _____ REVS / MIN		

<b>GENERAL INSPECTION</b> AS LISTED ON INSPECTION SCHEDULE ON NEXT PAGE	<b>PASS</b>	<b>COMMENTS</b>
<b>ITEMS</b>		

<b>NOISE TEST &amp; GENERAL INSPECTION</b> <b>ITEMS</b>	<b>FAIL</b>	<b>COMMENTS</b>

I certify that I have examined the above vehicle and have issued a PASS / FAIL as noted above.

LEAGUE CHIEF SCRUTINEER \_\_\_\_\_ Tel: \_\_\_\_\_

I certify that the above scrutineer has examined the above vehicle and issued a PASS / FAIL as noted above.

LEAGUE CHAIR \_\_\_\_\_ Tel: \_\_\_\_\_

For "PASS" THE FORM and INSPECTION SCHEDULE TO BE RETAINED BY COMPETITOR AND HANDED IN TO BAY 2 CLASS SCRUTINEER AT NAC  
If not presented then vehicle will be completely re-scrutineered at NAC.

The vehicle must be subject to the BAY 1 safety check at the NAC before proceeding to BAY 2.

For "FAIL" FORM TO BE RETAINED BY COMPETITOR UNTIL VEHICLE FAULTS HAVE BEEN REMEDIED AND VEHICLE RE-SCRUTINEERED AND A "PASS" ISSUED.

**NOTES**

It is the competitor's responsibility to ensure that the vehicle concerned complies with the NASA vehicle construction regulations. The original checked vehicle cannot be substituted by the use of another vehicle, unless authorised by the League Chair concerned. The substitute vehicle must be inspected and checked for compliance and seperately certified.

It is the League Chief Scrutineer's responsibility to ensure that the items listed have been checked for compliance with the NASA vehicle construction regulations in accordance with the NASA Scrutineering procedures.

It is the League Chair's responsibility to ensure that the items listed have been checked for compliance with the NASA vehicle construction regulations in accordance with the NASA Scrutineering procedures.

Random checks will be made at National Autograss Championship (NAC) to check validity of inspection schedule. Possession of form does not exempt vehicle from further scrutineering inspection.

Where the certification of compliance with the construction rules is found to be false and or an unauthorised vehicle substituted the competitor and/or driver of the vehicle concerned shall be disqualified and will be reported for disciplinary action. The Scrutineer and League Chair will also be reported.

CLASS 9 NASA - NATIONAL CHAMPIONSHIPS -- SCRUTINEERING PRE-CHECK LIST - 2013

\* CHECK LICENCE AND RULE BOOK FOR PREVIOUSLY LISTED FAULTS / COMMENTS \*

No.	GENERAL	P	F
1	NOISE + BRAKE TEST PASS STICKER.....		
2	IDENTIFICATION OK.....		
3	CLARITY OF NUMBERS/LETTERS.....		
4	BLACK ON WHITE PANEL / UPRIGHT.....		
<b>CHASSIS CONSTRUCTION: -</b>			
5	STEEL SPACEFRAME.....		
6	WITHSTAND COLLISION/ROLL ETC.....		
7	ROLL CAGE + BRACE BARS OK.....		
8	ROLL CAGE NOT MEDIUM FOR WATER..... / ELECTRICS.....		
9	ROLL CAGE FULLY WELDED.....		
10	ROOF WIDTH ABOVE 20"(510mm).....		
11	ROOF HEIGHT ABOVE 42"(1066mm).....		
12	REAR BRACE BAR 18"(457mm).....		
13	DIMENSION 'W' BELOW 2"(50mm).....		
14	FRONT BRACE BAR 4"(100mm).....		
15	SIDE PANEL 6"(150mm) ABOVE ELBOWS....		
16	DRIVER COMPARTMENT WIDTH		
17	(DIMENSION 'U') 24"(600mm) AT TOP.....		
18	DRIVERS HIPS DISTANCE 'V' 50mm.....		
19	SIDE PODS/BARS.....		
20	TOWING EYE 50mm @ FRONT + REAR.....		
21	FRONT FLAT+SIZE 8"(203mm) * 24"(600mm)..		
22	WHEEL CENTRE TO FRONT 24"(600mm).....		
23	DRIVERS FEET TO FRONT 9"(230mm).....		
24	NO FRONT PROTECTION.....		
25	REAR PROTECTION OK.....		
26	FUEL/OIL TANK PROTECTION.....		
27	BATTERY BOX (ALL BATTERIES) OK.....		
28	BATTERY CUT OFF SWITCH WORKING.....		
29	SCREEN MESH 1" * 1"(25mm * 25mm).....		
30	PERSPEX OUTSIDE FRONT SCREEN ONLY.....		
31	RADIATOR HEIGHT + FIT WITHIN AREA.....		
32	RADIATOR PROTECTION.....		
33	FUEL TANK & INTEGRAL TAP.....		
34	10 LITRE CAPACITY LIMIT.....		
35	VENT PIPE TO BELOW FLOOR.....		
36	FIRE HOLE IF TANK ENCLOSED.....		
37	NO FUEL/OIL/WATER LEAKS.....		
38	WHEEL STUDS FULL NUT THREAD.....		
39	WHEELS - CENTRE NOT CRACKED..... RIM OK - NO DAMAGE.....		
40	WHEEL SPACERS ONE PIECE SOLID.....		
41	TYRES Option 'A' or 'B' only.....		
42	TYRES - NO BULGES/CUTS.....		
43	SECONDARY FASTENINGS OK.....		
44	BALLAST OK.....		
45	NO SHARP PROJECTIONS.....		

No.	DRIVERS COMPARTMENT	P	F
46	CRASH HELM'T BS NUMB'RS.....		
47	CRASH HELM'T NOT PAINTED, STICKERED, DAMAGED.....		
48	ROLL CAGE 3" (75mm) ABOVE HELMET.....		
49	SAFETY HARNESS MIN 5 PT FIX.....		
50	NOT CUT/DAMAGED,BUCKLE OK		
51	HEAD RESTRAINT.....		
52	ARM RESTRAINT SYSTEM OK.....		
53	SEAT CORRECT.....		
54	SEAT SUPPORT+MOUNTINGS.....		
55	FIRE EXTINGUISHER CORRECT.....		
56	FIXED & WITHIN DRIVER REACH.....		
57	IGN SWITCH WITHIN DRIVER REACH.....		
58	STEEL FLOOR 2mm.....		
59	NO HOLES IN FLOOR.....		
60	FUEL/OIL/WATER PIPES COVERED.....		
61	FUEL TANK SHIELDED.....		
62	OIL/DRY SUMP TANK SHIELDED.....		
63	EXHAUST SHIELDED.....		
64	BRAKE PIPES SHIELDED		
65	AIR SCOOP 3"(75mm) * 18"(457mm)..		
<b>EXTERNALLY AT SIDE OF DRIVERS COMPARTMENT:</b>			
66	OIL/FUEL TANKS & BATTERIES ENCLOSED		
67	MIN 20mm BOX / 25mm CIRC. STEEL.....		
68	<b>ENGINE: SINGLE</b> CLASS cc LIMIT 1421 - 2070cc.		
69	NO MOTORBIKE ENGINE.....		
70	NOT M'BIKE DERIVED.....		
71	BORE/STROKE/cc LABEL TAG.....		
72	PROV FOR ENGINE SEALING.....		
73	CARB / Flnj RETURN SPRING.....		
74	CARB / Flnj PROTECTION BAR.....		
75	FULL SAFETY/FIRE SHIELD.....		
76	EXHAUST SYSTEM OK.....		
77	EXHAUST WITHIN SET AREA.....		
78	SILENCER OK.....		
79	OUTLET HORIZ / 30 Deg .....		
80	FLYWHEEL SHIELD OK.....		
81	ROTATING PULLEYS GUARD.....		
82	NO TRACTION CONTROL.....		

CAR NO ..... N.A.S.A. LEAGUE .....

PASS..... FAIL..... LEAGUE CHIEF SCRUTINEER.....

FORM TO BE RETAINED BY COMPETITOR AND PRESENTED AT NAC

NASA - NATIONAL CHAMPIONSHIPS -- SCRUTINEERING PRE-CHECK LIST - 2013

**CLASS:** 10

DRIVER NAME..... LICENCE No.....

VEHICLE NUMBER..... DATE: .....

**\* CHECK LICENCE AND RULE BOOK FOR PREVIOUSLY LISTED FAULTS / COMMENTS \***

<b>NOISE TEST</b> MAX = 102 Db (A)	<b>PASS</b>	<b>COMMENTS</b>
NOISE READING _____ Db (A) @ _____ REVS / MIN		

<b>GENERAL INSPECTION ITEMS</b> AS LISTED ON INSPECTION SCHEDULE ON NEXT PAGE	<b>PASS</b>	<b>COMMENTS</b>

<b>NOISE TEST &amp; GENERAL INSPECTION ITEMS</b>	<b>FAIL</b>	<b>COMMENTS</b>

I certify that I have examined the above vehicle and have issued a **PASS / FAIL** as noted above.

LEAGUE CHIEF SCRUTINEER \_\_\_\_\_ Tel: \_\_\_\_\_

I certify that the above scrutineer has examined the above vehicle and issued a **PASS / FAIL** as noted above.

LEAGUE CHAIR \_\_\_\_\_ Tel: \_\_\_\_\_

For "PASS" THE FORM and INSPECTION SCHEDULE TO BE RETAINED BY COMPETITOR AND HANDED IN TO BAY 2 CLASS SCRUTINEER AT NAC  
If not presented then vehicle will be completely re-scrutineered at NAC.

The vehicle must be subject to the BAY 1 safety check at the NAC before proceeding to BAY 2.

For "FAIL" FORM TO BE RETAINED BY COMPETITOR UNTIL VEHICLE FAULTS HAVE BEEN REMEDIED AND VEHICLE RE-SCRUTINEERED AND A "PASS" ISSUED.

**NOTES**

It is the competitor's responsibility to ensure that the vehicle concerned complies with the NASA vehicle construction regulations. The original checked vehicle cannot be substituted by the use of another vehicle, unless authorised by the League Chair concerned. The substitute vehicle must be inspected and checked for compliance and seperately certified.

It is the League Chief Scrutineer's responsibility to ensure that the items listed have been checked for compliance with the NASA vehicle construction regulations in accordance with the NASA Scrutineering procedures.

It is the League Chair's responsibility to ensure that the items listed have been checked for compliance with the NASA vehicle construction regulations in accordance with the NASA Scrutineering procedures.

Random checks will be made at National Autograss Championship (NAC) to check validity of inspection schedule. Possession of form does not exempt vehicle from further scrutineering inspection.

Where the certification of compliance with the construction rules is found to be false and or an unauthorised vehicle substituted the competitor and/or driver of the vehicle concerned shall be disqualified and will be reported for disciplinary action. The Scrutineer and League Chair will also be reported.

**CLASS 10 NASA - NATIONAL CHAMPIONSHIPS -- SCRUTINEERING PRE-CHECK LIST - 2013**

**\* CHECK LICENCE AND RULE BOOK FOR PREVIOUSLY LISTED FAULTS / COMMENTS \***

No.	<u>GENERAL</u>		
		P	F
1	NOISE + BRAKE TEST PASS STICKER.....		
2	IDENTIFICATION OK.....		
3	CLARITY OF NUMBERS/LETTERS.....		
4	BLACK ON WHITE PANEL / UPRIGHT.....		
<b><u>CHASSIS CONSTRUCTION: -</u></b>			
5	STEEL SPACEFRAME.....		
6	WITHSTAND COLLISION/ROLL ETC.....		
7	ROLL CAGE + BRACE BARS OK.....		
8	ROLL CAGE NOT MEDIUM FOR WATER..... / ELECTRICS.....		
9	ROLL CAGE FULLY WELDED.....		
10	ROOF WIDTH ABOVE 20"(510mm).....		
11	ROOF HEIGHT ABOVE 42"(1066mm).....		
12	REAR BRACE BAR 18"(457mm).....		
13	DIMENSION 'W' BELOW 2"(50mm).....		
14	FRONT BRACE BAR 4"(100mm).....		
15	SIDE PANEL 6"(150mm) ABOVE ELBOWS....		
16	DRIVER COMPARTMENT WIDTH		
17	(DIMENSION 'U') 24"(600mm) AT TOP.....		
18	DRIVERS HIPS DISTANCE 'V' 50mm.....		
19	SIDE PODS/BARS.....		
20	TOWING EYE 50mm @ FRONT + REAR.....		
21	FRONT FLAT+SIZE 8"(203mm) * 24"(600mm)...		
22	WHEEL CENTRE TO FRONT 24"(600mm).....		
23	DRIVERS FEET TO FRONT 9"(230mm).....		
24	NO FRONT PROTECTION.....		
25	REAR PROTECTION OK.....		
26	FUEL/OIL TANK PROTECTION.....		
27	BATTERY BOX (ALL BATTERIES) OK.....		
28	BATTERY CUT OFF SWITCH WORKING.....		
29	SCREEN MESH 1" * 1"(25mm * 25mm).....		
30	PERSPEX OUTSIDE FRONT SCREEN ONLY.....		
31	RADIATOR HEIGHT + FIT WITHIN AREA.....		
32	RADIATOR PROTECTION.....		
33	FUEL TANK & INTEGRAL TAP.....		
34	10 LITRE CAPACITY LIMIT.....		
35	VENT PIPE TO BELOW FLOOR.....		
36	FIRE HOLE IF TANK ENCLOSED.....		
37	NO FUEL/OIL/WATER LEAKS.....		
38	WHEEL STUDS FULL NUT THREAD.....		
39	WHEELS - CENTRE NOT CRACKED..... RIM OK - NO DAMAGE.....		
40	WHEEL SPACERS ONE PIECE SOLID.....		
41	TYRES Option 'A' or 'B' only.....		
42	TYRES - NO BULGES/CUTS.....		
43	SECONDARY FASTENINGS OK.....		
44	BALLAST OK.....		
45	NO SHARP PROJECTIONS.....		

No.	<u>DRIVERS COMPARTMENT</u>		
		P	F
46	CRASH HELM'T BS NUMB'RS.....		
47	CRASH HELM'T NOT PAINTED, STICKERED, DAMAGED.....		
48	ROLL CAGE 3" (75mm) ABOVE HELMET.....		
49	SAFETY HARNESS MIN 5 PT FIX.....		
50	NOT CUT/DAMAGED,BUCKLE OK		
51	HEAD RESTRAINT.....		
52	ARM RESTRAINT SYSTEM OK.....		
53	SEAT CORRECT.....		
54	SEAT SUPPORT+MOUNTINGS.....		
55	FIRE EXTINGUISHER CORRECT.....		
56	FIXED & WITHIN DRIVER REACH.....		
57	IGN SWITCH WITHIN DRIVER REACH.....		
58	STEEL FLOOR 2mm.....		
59	NO HOLES IN FLOOR.....		
60	FUEL/OIL/WATER PIPES COVERED.....		
61	FUEL TANK SHIELDED.....		
62	OIL/DRY SUMP TANK SHIELDED.....		
63	EXHAUST SHIELDED.....		
64	BRAKE PIPES SHIELDED		
65	AIR SCOOP 3"(75mm) * 18"(457mm).....		
<b><u>EXTERNALLY AT SIDE OF DRIVERS COMPARTMENT:</u></b>			
66	OIL/FUEL TANKS & BATTERIES ENCLOSED		
67	MIN 20mm BOX / 25mm CIRC. STEEL.....		
68	<b><u>ENGINE: SINGLE/TWIN</u></b>		
69	CLASS cc N. ASP MIN: 2071cc FORCED IND MINcc:FREE SINGLE NOT M'BIKE		
70	CARB / FI RETURN SPRING.....		
71	CARB / FIinj PROTECTION BAR.....		
72	FULL SAFETY/FIRE SHIELD.....		
73	EXHAUST SYSTEM OK.....		
74	EXHAUST WITHIN SET AREA.....		
75	SILENCER OK.....		
76	OUTLET HORIZ / 30 Deg .....		
77	CHAIN GUARD.....		
78	ROTATING PULLEYS GUARD.....		
79	FLYWHEEL SHIELD OK.....		
80	NO TRACTION CONTROL.....		

CAR NO ..... N.A.S.A. LEAGUE .....

PASS..... FAIL..... LEAGUE CHIEF SCRUTINEER.....

FORM TO BE RETAINED BY COMPETITOR AND PRESENTED AT NAC