



# NATIONAL AUTOGRASS SPORT ASSOCIATION LTD.

NASA --- SCRUTINEERS COMMITTEE MEETING

REF: S2MIN0414/DH/WB/GIJ

SATURDAY, 12th APRIL 2014 - 11.00 am

METRO INN, Birmingham Road, Walsall WS5 3AB

Present

C. SCRUTINEERS	No.	LEAGUE	SCRUTINEERS CLUB
Y	16	CGTRO(LINCOLN)	CGTRO
*	25	C. SCOTLAND	Wsx
Y	14	EAST ANGLIA	
Y	01	EAST MIDLANDS	
*	11	ESSEX	
Y	24	FENLAND	
+Y	02	GLOUCESTER	
	18	KENT	
Y	07	MIDLAND AP	
+Y	09	NORTH WESTERN	
*	21	NORTHERN IRELAND	
*	10	NORTH YORKSHIRE	
*	15	SHROPSHIRE AA	
*	04	SOUTH WALES	
*	19	THE DALES	
Y	05	SOUTHERN	
*	23	IRELAND	
Y	13	WEST WALES	
*	06	WEST MIDLANDS	
*	22	WILTSHIRE	
*	12	YORKSHIRE	

NASA Chief Scrutineer/Director  
NASA National Scrutineer/Scrutineering Assistant  
NASA National Scrutineer/Scrutineering Assistant  
NASA Director

APOLOGIES: Scrut. Sec.

Scrutineers marked + are Club scrutineers representing League in place of League Chief Scrutineer.

VISITORS:

**ASSOCIATION OF  
AUTHORISING  
BODIES**

Office: 46 Brookside, Alconbury, Huntingdonshire PE28 4EP  
Registered in England and Wales – Company No. 1716574

**Note.**

*The minutes have been compiled by Scrutineer Sec. based upon notes taken at and narrative of the meeting by others.*

1. **INTRODUCTION.** – The NASA Chief Scrutineer welcomed those present.

2. **MINUTES OF PREVIOUS MEETING 16/02/14 and MATTERS ARISING**

Page 1. – Delegated powers.

Director WB and NASA Chief Scrutineer explained that that this was at Board. Ideally the National Scrutineers should be able to make scrutineering decisions on in the absence of, and thus behalf of The Chief Scrutineer. However The National File limited their powers.

Page 3. - The CGTRO rep. mentioned that we should be looking at reducing the noise level from 102dbs to ?

Page 4. - No rule change to the Micras.

Page 5. - NASA Chief Scrutineer Explained the door number rule. Must be compliant with rules. No lower case or overlapping letters.

Page 5. - Class 8 cc to change from 1350cc to ?

NASA Chief Scrutineer confirmed that there will be no change to 1350cc limit.

Page 7. - Radiator location on Mr VG special.

NASA Chief Scrutineer confirmed location non-compliant. Mr VG upset and disappointed that car had raced previously and this had not been picked up in the last 10 years.

Page 8. – Steering Rack location.

The EM rep. mentioned about the position of some steering racks in open wheel classes being mounted to the floor. NASA Chief Scrutineer confirmed that this is non-compliant. The rack must be mounted to vehicle chassis.

Page 9. – Measuring equipment.

NASA also investigating the purchase of a bore measuring device (Used in USA Sprint Racing) that a competitor has information on. This will allow some engines to have bore & stroke checked via central plug hole without removing cylinder head. If any doubt on accuracy then head will be removed.

The room felt it would be a good idea NASA Chief Scrutineer was going to speak with competitor concerned. The NASA Chief Scrutineer believed that Director LE had the brochure.

There were no other matters arising.

PROPOSED: CGTRO Rep.

SECONDED: Glos. Rep.

That the minutes be accepted as a true record.

**UNANIMOUS**

3. **CORRESPONDENCE:** - None

4. **JANUARY 2014 EDITION NASA VEHICLE CONSTRUCTION RULES AND REGULATIONS**

a. **Class 1 & 2.**

**Experimental vehicles / Trials.**

The CGTRO rep. explained that an approach had been made regarding a Fiesta DOHC for an experimental vehicle in Class 2. Could this be considered?

NASA Chief Scrutineer will consider it but requires more information of vehicle.

b. **Tyres**

**Tyre Update.**

The Tyre co-ordinator & EM rep. explained that situation was as at previous meeting. An up to date tyre list had been sent several times to webmaster JB to upload on the NASA web site.

Director WB asked Tyre Co-ordinator to send the list to NASA Chief Scrutineer.

c. **Chief Scrutineer Report.**

Roll cages. – 2015 Rules

NASA Chief Scrutineer and Director WB explained that the rule change for 2015 – banning 25mm box, is to continue.

There were comments, representing their League/Club members feelings, that indicated some remained not in favour of this change – Would kill sport. Many vehicles still had 25mm box cages and would be scrapped. Survey at recent

club race meeting indicated greater number of box cages as opposed to circular tube. The CGTRO rep. queried whether insurance company would permit continuation of old rule.

NASA Chief Scrutineer and Director WB confirmed Board decision to proceed.

#### **d. Rules Clarification requests from League C. Scrutineers**

##### Class 1

Micra Vehicle – Cylinder Head.

It was mentioned that there are different Micra heads for class 1. Hence maybe 2 different head thickness measurements.

- NASA Chief Scrutineer to investigate.

Mini Vehicles – Exhausts.

NASA Chief Scrutineer explained that mini spares have been manufacturing split exhaust systems as a standard replacement item. He will investigate further prior to deciding on its use.

*Subsequent to meeting NASA Chief Scrutineer contacted Mini Spares and they confirmed that the system is standard replacement and is split due to long length. The smaller/shorter split lengths enable delivery to take place via courier/post etc.*

NASA Chief Scrutineer confirms that this system is permitted.

---

**Not mentioned at meeting but provided for information. - WARNING.**

##### Class 1

##### Competition Head gaskets.

*The use of competition head gaskets in any class 1 vehicle is not permitted.*

*Any vehicle found with such a gasket will be disqualified and competitor concerned reported for disciplinary action.*

##### Yaris Vehicle.

*See attached page at end of minutes for details of scrutineering checks required on induction system.*

---

Class 5. – Mudguards.

York scrutineer had failed a class 5 on the mud guard rule.

Class 7.

Query raised regarding construction of Mr CM's new vehicle – Is rear beam compliant?

The EM rep. agreed to investigate/check.

## **5. Proposed changes for January 2015 as recommended by the Scrutineers Committee.**

### **N.B.**

The items minuted are the proposed subject of the rules in question, **details of discussions, and alternatives involved have not been recorded** as their inclusion may produce confusion.

A handout of the ratified changes will be issued later in year. – Interim information below.

1. Amend Class 1 rule wording regarding Micra & Yaris door skinning and window runner skinning – 1<sup>st</sup> Draft

# Nissan Micra 998cc 16v. & Toyota Yaris 998cc 16v

Door tops (Window Frames):

The outer window top skin must be retained and remain in situ.

The inner window "U" shaped runners and internal frame/skin may be removed.

2. Amend Class 1 & 2 rule wording to clarify situation regarding 4/5 door bodyshells

2.1. All vehicles must be of metal and retain their original shape and silhouette (Including height, width and length) as per manufacturer's original specifications, including engine compartment bonnet or cover. De-Seaming prohibited.

The bodyshell must remain as its original type as produced by the original manufacturer. The conversion of a 2 or 3 door model to a 4 or 5 door model and vice-versa is prohibited. e.g. If a vehicle as originally manufactured is a 5 door hatchback it must remain as a 5 door hatchback the conversion to a 2 door saloon or a 3 door hatchback or non-original door configuration is prohibited.

#### Rear passenger Compartment Doors.

For "4 door" and or "5 door" vehicles the rear passenger's compartment doors (Nearside and offside) must remain as original. "skinning" prohibited. See Rule 2.1.

### 3. Amend Specials radiator rule wording – 1<sup>st</sup> Draft

22.7 Where the radiator(s) is/are fitted behind or to the rear of the driver, it (they) must be to the rear of the front face of the rear roll cage upright, and be below the top face of the rear brace bars and be within the shaded area shown on Fig.18. ~~It must be beneath the line, drawn between A (The centre of the axle) and B (The top of the rear hoop). Or, if fitted outside this line, the top of the radiator must not exceed 2ft 0" (610mm) from the ground, or 6" (150mm) above the top of the rocker cover, whichever is the higher.~~ (See Rules 22.8 & 22.13).

22.8 Radiators fitted at the rear of specials must also have radiator protection bars fitted. (See 22.13).

**Note.** Rear brace bars may suffice as protection bars if they are above the radiator.

#### 22.13 Radiator Protection.

Where radiators are fitted at the rear of Specials, and are to the rear of the rear brace bars it (they) must be within the shaded area as shown on Fig.18. and be fitted such that they are with 1metre (33") of the ground when vehicle at standstill. If it (they) protrudes either beyond the rear brace bars or main chassis, for safety and protection of following competitors, the radiators must be adequately protected, with ~~the~~ a framework consisting of a minimum of 1" (25mm) box or 1¼" (32mm) circular/tubular. (See Fig.18).

### 4. Amend towing eye wording – 1<sup>st</sup> Draft.

#### Towing Eye.

The fitting of a 'Towing Eye' at the front and rear of the vehicle is mandatory. **Maximum Specified metal 'Eye' diameter is 50mm. For other materials a minimum 50mm, maximum 100mm "Loop" is specified.** The 'Towing Eye' must not protrude beyond the vehicle bodyline. 'Towing Eyes' and 'Towing Eye fixings' that are excessively sized or that can be regarded as 'ballast' or 'protection' are prohibited. The original standard production item may be retained or removed or bent downwards so as not to protrude beyond the bodyline

5. Revision of format as per Board instructions.

#### a. Rules Change requests from League Chief Scrutineers & Leagues. - None brought to meeting.

*Note: Leagues may submit any required rule changes for 2015, to this committee for discussion during 2014.*

#### b. Rules Change request from NASA Chief Scrutineer. – None since previous meeting.

#### c. Rules change requests from NASA Directors. - None since previous meeting.

### 6. ANY OTHER BUSINESS:

#### **National Autograss Championships 2014**

Letters to all League Chief Scrutineers present were handed out requesting names of scrutineers for the 2014 NAC and 2014 Ladies & Jnr. NAC's. Brief discussion followed on duties and workload and catering facilities at nationals.

The WW rep. asked about the scrutineering times at both the ladies and gents nationals as different times were being bandied around. Director WB and NASA Chief Scrutineer suggested we stick with those already agreed. See Scrutineering times guide in reminders section at end of minutes.

Letters to all League Chief Scrutineers not at meeting will be issued via email (To those who's emails are known) requesting names of scrutineers for the 2014 NAC and 2014 Ladies & Jnr. NAC's.

Names to be returned to Scrutineer Sec. ASAP as the scrutineers will be allocated to their respective classes at the next meeting.

#### **Note:**

**The Pre-checking of vehicles attending the NAC's by League & Club Scrutineers is required.**

#### **"Men's" Nationals.**

"Brake testing" personnel approx 6 persons required from "Host" league to assist NASA Scrutineers.

#### **"L & J" Nationals.**

"Brake testing" personnel approx 6 persons required from "Host" league to assist NASA Scrutineers.

The Club will be providing required personnel to assist NASA Scrutineers.

MEETING CLOSED 2.20 p.m.

N.B. REMINDERS:

1. **Next Meeting:**

Names of those wishing to scrutineer at both the NAC's and L & J NAC's must be brought to the meeting, in order to allocate personnel to each class. League Chief Scrutineers should assist at the NAC's.

2. **Rule Book & Licence.**

All members must be accompanied by their Rule Book and Licence at all times at a race meeting. Both the members Rule Book and Licence must be presented at "Scrutineering" and "Signing on" There must be a photograph of the member placed on the Licence.

4. **JUNIORS - Rule Book & Licence.**

All Junior Drivers must be accompanied by their Letter/Form of consent to race and Rule Book and Licence at all times at a race meeting.

The Letter/Form of Consent, Rule Book and Licence must be presented at "Scrutineering" and "Signing on"

There must be a photograph of the member placed on the Licence.

**"Orange" "Official" scrutineers jackets**

Not all "orange" "official" scrutineers jackets have been returned to Mr G. Jones following the National Championships. Could they please be returned as soon as possible.

**These jackets are intended for use at the National Championship Meetings only.**

They have not been generally issued to Clubs or Leagues for use locally.

If any are seen at race meetings then the Leagues concerned may be charged a certain sum of money and the jackets confiscated.

**2014 National Autograss Championships**

St Florence.  
Nr Tenby, Pembrokeshire  
SA70 8SY  
[www.2014nationals.co.uk](http://www.2014nationals.co.uk)

1<sup>st</sup> 2<sup>nd</sup> & 3<sup>rd</sup> August 2014.

Scrutineering times:  
(All to be confirmed)

FRIDAY: Noise Testing

2.00 p.m. -- 3.30 p.m. (Break 3.30 - 4.30)  
4.30 p.m. -- 7.30 pm.

FRIDAY: Scrutineering

2.00 p.m. -- 4.00 p.m. (Break 4.00 – 5.00)  
5.00 p.m. -- 8.00 pm

SATURDAY: Noise Testing

7.30 a.m. -- 8.30 a.m.

SATURDAY: Scrutineering

8.00 a.m. -- 9.00 a.m.

SUNDAY: Scrutineering

8.30 a.m. -- 9.00 a.m. (Repaired vehicles only)

**2014 Ladies & Junior National Autograss Championships**

Magor Raceway. Nr  
Newport, Monmouthshire.  
NP26 3RA (Off Jn. 23a M4)  
[www.2014nationals.co.uk](http://www.2014nationals.co.uk)

29<sup>th</sup> 30<sup>th</sup> & 31<sup>st</sup> Aug 2014.

Scrutineering times:  
(All to be confirmed)

FRIDAY: Noise Testing

2.00 p.m. -- 3.30 p.m. (Break 3.30 - 4.30)  
4.30 p.m. -- 7.00 pm.

FRIDAY: Scrutineering

2.00 p.m. -- 4.00 p.m. (Break 4.00 – 5.00)  
5.00 p.m. -- 7.30 pm

SATURDAY: Noise Testing

7.30 a.m. -- 8.00 a.m.

SATURDAY: Scrutineering

7.30 a.m. -- 8.00 a.m.

SUNDAY: Scrutineering

8.30 a.m. -- 9.00 a.m.

(Repaired vehicles only)

**NOTE:**

Any scrutineer who wishes to take part in scrutineering duties at the NAC's must attend at least one scrutineers committee meeting.

1. Scrutineers must give all assistance required to drivers/constructors in preparing vehicles to comply with the 2014 Edition Rule Book.
2. For future reference: **WANTED:**  
Details, photographs, etc. of reasons for vehicles to fail scrutineering, examples of incorrect or dangerous practices.

**3 FUTURE MEETINGS: 11.00 am**

**Metro Inn, Birmingham Rd, Walsall WS5 3AB**

SATURDAY	28 June 2014	NAC's & Training
SATURDAY	04 October 2014	2015 Rules - Confirmation

**NASA AGM 30 November 2014**

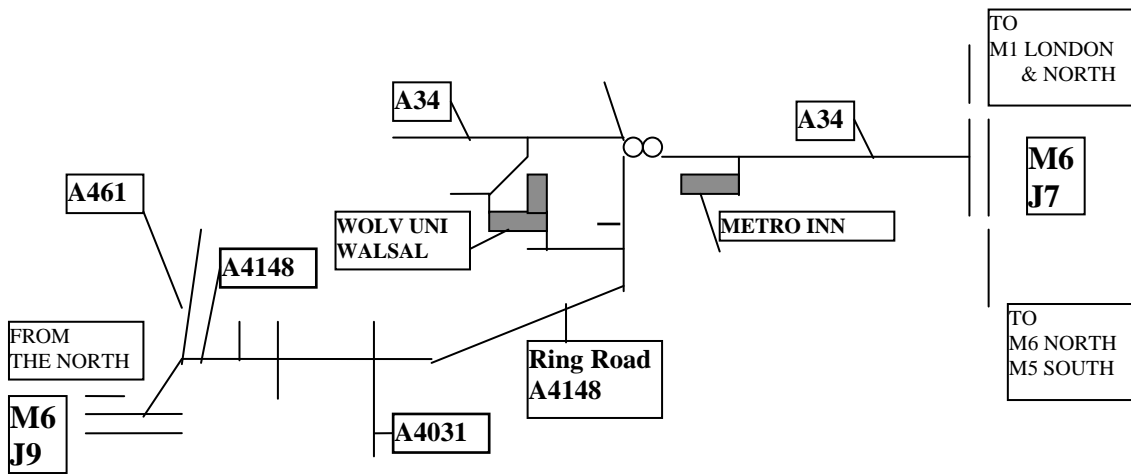

People attending the meeting must park their vehicles in CAR PARK. PLEASE DO NOT PARK ON THE GRASS.

Follow signs to RECEPTION, receptionist will then direct you to the correct room.

**You are advised to bring your own refreshments.**

**The travelodge has a NO-SMOKING rule.**

4. Comments required from leagues on:  
NASA Rules & Regulations - Clarification's, Changes for future etc.

=====

TOYOTA YARIS - Under bonnet View.

Underbonnet view of a 1.0 litre engine model

- 1 Brake/clutch fluid reservoir
- 2 Power steering pressure switch
- 3 Engine right-hand mounting
- 4 Washer fluid reservoir
- 5 Engine oil filler cap
- 6 Air cleaner housing
- 7 Canister purge valve
- 8 Charcoal canister
- 9 Heater hose
- 10 Gearchange cables
- 11 Engine compartment fusebox
- 12 Battery negative terminal
- 13 Air inlet duct
- 14 Coolant expansion tank
- 15 Radiator top hose
- 16 Horn
- 17 Radiator pressure cap
- 18 Bonnet lock
- 19 Exhaust manifold
- 20 Clutch bleed screw
- 21 Engine oil dipstick
- 22 Ignition coil
- 23 Power steering fluid reservoir
- 24 Accelerator cable

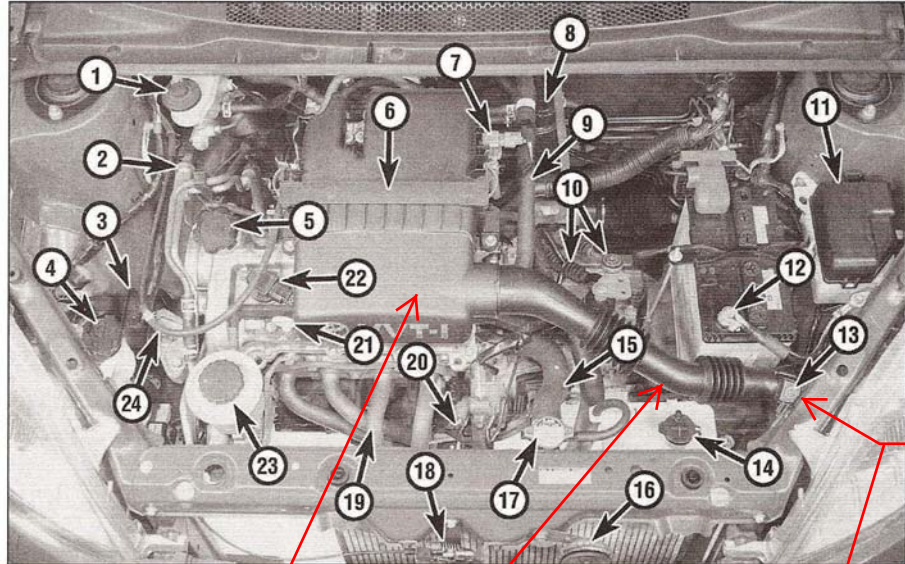

Scrutineering check:  
Duct must have trumpet type end and must terminate approx this point.

Scrutineering check:  
Check filter housing for any cuts or holes.

Scrutineering check:  
Check duct has not been shortened or has been cut or holes drilled/cut into it. Check flexibles for razor blade cuts.



Underbonnet view of a 1.3 litre (2NZ-FE) engine model

- 1 Brake/clutch fluid reservoir
- 2 Brake servo vacuum hose
- 3 Power steering fluid reservoir
- 4 Engine oil filler cap
- 5 Fuel supply hose
- 6 Canister purge valve
- 7 Air cleaner housing
- 8 Engine compartment fusebox
- 9 Battery negative terminal
- 10 Accelerator cable
- 11 Air conditioning sight glass
- 12 Coolant expansion tank
- 13 Automatic transmission fluid dipstick
- 14 Radiator hose
- 15 Radiator pressure cap
- 16 Engine oil dipstick
- 17 Inlet manifold
- 18 Alternator
- 19 Washer fluid reservoir
- 20 Engine right-hand mounting

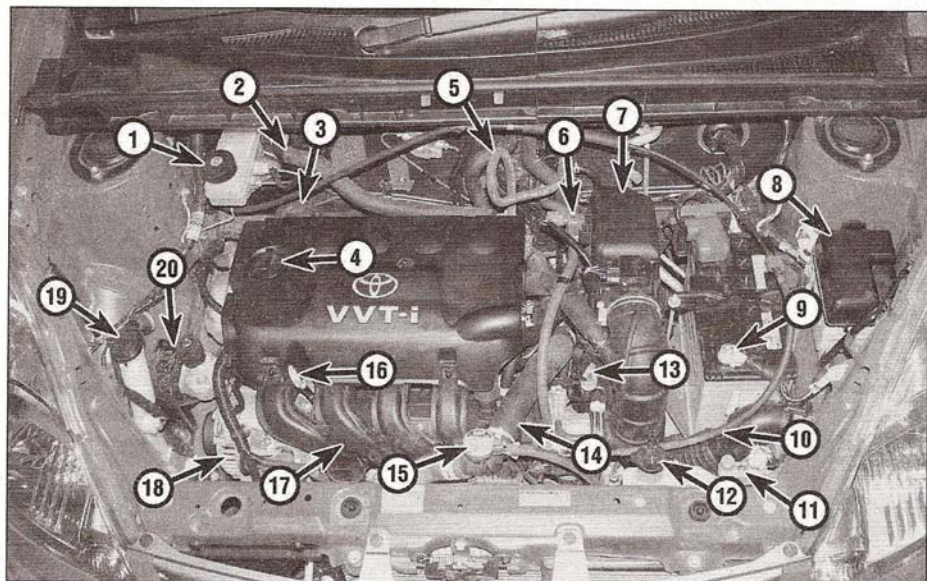

1.3 engine not allowed in Class 1.