

NATIONAL AUTOGRASS SPORT ASSOCIATION LTD



SCRUTINEERS COMMITTEE MEETING

REF: S3MIN0615/RS/GIJ

SUNDAY, 27th JUNE 2015 - 11.00 am

METRO INN, Birmingham Road, Walsall WS5 3AB.

Present

C. SCRUTINEERS	No.	LEAGUE	SCRUTINEERS CLUB
Y	16	CGTRO(LINCOLN)	ST
*	25	C. SCOTLAND	SW
Y	14	EAST ANGLIA	W
Y	01	EAST MIDLANDS	
Y	11	ESSEX	
*	24	FENLAND	
Y	02	GLOUCESTER	
*	18	KENT	
Y	07	MIDLAND AP	
Y	09	NORTH WESTERN	
*	21	NORTHERN IRELAND	
Y	10	NORTH YORKSHIRE	
*	15	SHROPSHIRE AA	
*	04	SOUTH WALES	
*	19	THE DALES	
Y	05	SOUTHERN	
*	23	IRELAND	
*	13	WEST WALES	
Y	06	WEST MIDLANDS	
*	22	WILTSHIRE	
Y	12	YORKSHIRE	

NASA Deputy Chief Scrutineer.
NASA Director – Scrutineering.

APOLOGIES: Scrut Sec, WW Cs, Cl1 Cs, Cl10 Cs

Scrutineers marked + are Club scrutineers representing League in place of League Chief Scrutineer.
VISITORS:

**ASSOCIATION OF
AUTHORISING
BODIES**

Office: 46 Brookside, Alconbury, Huntingdonshire PE28 4EP
Registered in England and Wales – Company No. 1716574

1. INTRODUCTION.

NASA Deputy Chief Scrutineer welcomed those present, and thanked them for attending.

2. MINUTES OF PREVIOUS MEETING - 11/04/15 and MATTERS ARISING:

Page 1. – Rear Cross Beam

Confirmation on Rear beam. Additional beam of roll cage spec if 38mm is not between uprights.

Page 1. – Class 1 Electronic ignition trial – Update further in meeting.

Page 1. Competitor Roll Cage.

The CGTRO Rep. expressed concerns about Mr R.T.'s Cage.

Discussion that it had been accepted at a previous meeting which the CGTRO Rep. was absent to. Accepted under conditions of no more being built.

Page 2. Rule book being made easier to understand.

There were no other matters arising.

PROPOSED: CGTRO

SECONDED: EA

That the minutes be accepted as a true record.

UNANIMOUS

CARRIED

3. CORRESPONDENCE:

1. Mr P. Hinton – Request to run an experimental 1.3 Toyota Yaris in Class 2. This is ongoing, CI 1 Cs dealing with.

Additional Class 2 experimental enquiry from Mr S. Carr, Micra K11 1.3.
CI1 Cs original idea for class 2.
CI1 Cs dealing with this too.

There was no other correspondence received.

4. VEHICLE CONSTRUCTION RULES & REGULATIONS.

a. Class 1: Experimental contactless ignition update.

Mr VM (Dir). Ref email from someone trying the Aldon LU144 £90 from Mini World. They had found no gain in power, but improved reliability. They were booked into dyno and would report back.

Class 2.: Experimental vehicles / Trials.

Current Class 2 experimental Polo of Mr B. Ellis.
Concerns of condition etc. CI1 Cs watching.

b. Tyres – Update / Testing.

The Tyre Co-ordinator explained that :

Testing last year was OK.

Concerns on tyre wear this year, He will be checking suppliers on their stock hardness.

10" Mini tyres – Sportway had none.

Possible supplier of new Hakka style 10" from Tredex. They could have them in 5 weeks from China.

c. Scrutineering Report.

- i. General Roll Cage construction issues inc. Head Clearance / Measurement holes / Rear Cross Bar.

Head clearance need to be checked more thoroughly.

Rear Cross beam discussed earlier.

Roll Cage testing so far failure rate less than 10% approx.

ii. Seat harness: Fixings – Class 4 & 5. / Harness angles – Juniors.

Too much harness to shoulder gap is being found on some Juniors & Ladies.

This has to be rectified and belts closer to shoulders.

Additional drivers must be present at scrutineering to check fitment.

Crutch Strap fixing. Single point must not go backwards.

(Picture shown of seat that had been ripped open through base).

Seats and belts to be on separate fixing points.

Look at stopping seat belts being attached to floorpan and fixed to more substantial material.

i.e. Floor frame and Roll Cage.

ii. Throttle operation.

Checking of throttle returning correctly. – Engine off and check for full and free return.

iv. Door Identification/numbers.

Must be readable.

v. Front panels – Mini.

Noted Mini front panels are not as rule book Class 1 & Class 4567 (Fig 17.). Enforcement needed.

National Autograss Championships 2015

i. Club & League responsibilities. - Club and League all in hand.

ii. General.

3 Scrutineers per class on lanes plus someone doing paperwork.

Any illegality to be refused.

Class 1 Scrutineer needed – Mr T. A.

Class 2 Scrutineer needed. Someone possible but not confirmed.

Noise Test. - Mr R.H. offered to help Mr G.M. on noise testing with the new machine.

Scrutineers.

A letter is sent in April/May to each League Chief Scrutineer requesting names, for duties at the NAC's.

Some Leagues have already replied - Any more??

For allocation list - See page 12. *Note. Volunteer scrutineers will be given gate refund and award for "Working" at NAC's.*

The gasket costs will only be paid for vehicles stripped on the day on the field.

Up to a maximum of : Class 1 & 2 £50, Class 3 - 10 £50.

Oil allowance of: All Classes - £20.

Bay 1 - Host league to supply 6 persons for brake/safety checks.

Bay 2 – Host league to supply 10 no "Signing on" persons – 1 per class.

General discussion followed on duties and workload at nationals.

See Scrutineering times guide in reminders section at end of minutes.

"Men's" Nationals.

"Brake testing" personnel approx 6 persons required from "Host" league to assist NASA Scrutineers.

“L & J” Nationals.

“Brake testing” personnel approx 6 persons required from “Host” league to assist NASA Scrutineers.
The Club will be providing required personnel to assist NASA Scrutineers.

*Note. The Pre-Season check sheets may be used to pre-scrutineer vehicles for 2015 Nationals for competitors/officials.
They are on NASA website for downloading.*

2 pages per Class. First page = Main compliant sheet for “Signing of”. Second Page = Items for checking and “signing off”.
Alternatively League scrutineers that have been sent copies may forward on to competitors..

e. Rules Clarification requests from League Scrutineers.

None

5. DRAFT RULE CHANGES:

Mr VM (Dir) explained that the rule changes for 2016 were due for discussion at Board.

- a. Rule change requests from Leagues. – None
- b. Rule change requests from Chief Scrutineer. – None additional to above.
- c. Rule change requests from Board of Directors. – None additional to above.

6. ANY OTHER BUSINESS:

MAP Rep. Concerns on front engined specials. Should we be stopping them?

Class 3 wheelbase. Email to VM (Dir) on additional wheel base types.

Wheel arch concerns to stones etc; being flicked into public. Look into possible mudflap fitting.

Additional air filter over the end of Micra air pipes not acceptable, but foam or gauze pre-filter OK.

Battery location in front cradle, but not forward of it.

Pull cords on “Cut off” switches to be checked more thoroughly. - Cables corroding.

The NW Rep. asked if tyre warmers can be used? - Answer No they cannot.

The NY Rep. noted that some special brake pedals are being mounted with only 6mm bolts. (Bars shown of item removed from car).

Special bonnets to be removed for checking of fixings.

Seat fixing points not substantial enough. Checking needed.

Confirmation of diagnostic plug on Micra. – YES must be there as it shows if temperature sensor has been removed.

Mr VM (Dir) showed sump guard that had fallen off a special. It had 10mm plates tack welded to it.
This is not acceptable and not secure.

Meeting Closed 1.45 p.m.

N.B. REMINDERS:

1. **Next Meeting:**

2. **Rule Book & Licence.**

All members must be accompanied by their Rule Book and Licence at all times at a race meeting. Both the members Rule Book and Licence must be presented at "Scrutineering" and "Signing on" There must be a photograph of the member placed on the Licence.

4. **JUNIORS - Rule Book & Licence.**

All Junior Drivers must be accompanied by their Letter/Form of consent to race and Rule Book and Licence at all times at a race meeting.

The Letter/Form of Consent, Rule Book and Licence must be presented at "Scrutineering" and "Signing on"

There must be a photograph of the member placed on the Licence.

"Orange" "Official" scrutineers jackets

Not all "orange" "official" scrutineers jackets have been returned to Mr G. Jones following the previous years National Championships. Could they please be returned as soon as possible or brought to the National Championships for re-use.

These jackets are intended for use at the National Championship Meetings only.

They have not been generally issued to Clubs or Leagues for use locally.

If any are seen at race meetings then the Leagues concerned will be charged a certain sum of money and the jackets confiscated.

2015 National Autograss Championships

Thinghill Court
Withington, Hereford.
HR1 3QG
Access from A465 only.
www.national-autograss.co.uk

31^s July & 1st & 2nd August 2015.

Scrutineering times:
(All to be confirmed)

FRIDAY: Noise Testing

2.00 p.m. -- 3.30 p.m. (Break 3.30 - 4.30)
4.30 p.m. -- 7.30 pm.

FRIDAY: Scrutineering

2.00 p.m. -- 4.00 p.m. (Break 4.00 – 5.00)
5.00 p.m. -- 8.00 pm

SATURDAY: Noise Testing

7.30 a.m. -- 8.30 a.m.

SATURDAY: Scrutineering

8.00 a.m. -- 9.00 a.m.

SUNDAY: Scrutineering

8.30 a.m. -- 9.00 a.m.
(Repaired vehicles only)

2015 Ladies & Junior National Autograss Championships

Hillside House Raceway.
Nr Thornborough.
DL8 2RE
Access from B6267 only.
www.ydautograss.co.uk

4th 5th & 6th September 2015.

Scrutineering times:
(All to be confirmed)

FRIDAY: Noise Testing

2.00 p.m. -- 3.30 p.m. (Break 3.30 - 4.30)
4.30 p.m. -- 7.00 pm.

FRIDAY: Scrutineering

2.00 p.m. -- 4.00 p.m. (Break 4.00 – 5.00)
5.00 p.m. -- 7.30 pm

SATURDAY: Noise Testing

7.30 a.m. -- 8.00 a.m.

SATURDAY: Scrutineering

7.30 a.m. -- 8.00 a.m.

SUNDAY: Scrutineering

8.30 a.m. -- 9.00 a.m.
(Repaired vehicles only)

NOTE:

Any scrutineer who wishes to take part in scrutineering duties at the NAC's must attend at least one scrutineers committee meeting.

1. Scrutineers must give all assistance required to drivers/constructors in preparing vehicles to comply with the 2015 Edition Rule Book.
2. For future reference: **WANTED:**
Details, photographs, etc. of reasons for vehicles to fail scrutineering, examples of incorrect or dangerous practices.
- 3 **FUTURE MEETINGS: 11.00 am**
Metro Inn, Birmingham Rd, Walsall WS5 3AB

SATURDAY

03rd OCTOBER

2016 Rules - Confirmation

NASA AGM 29 November 2015

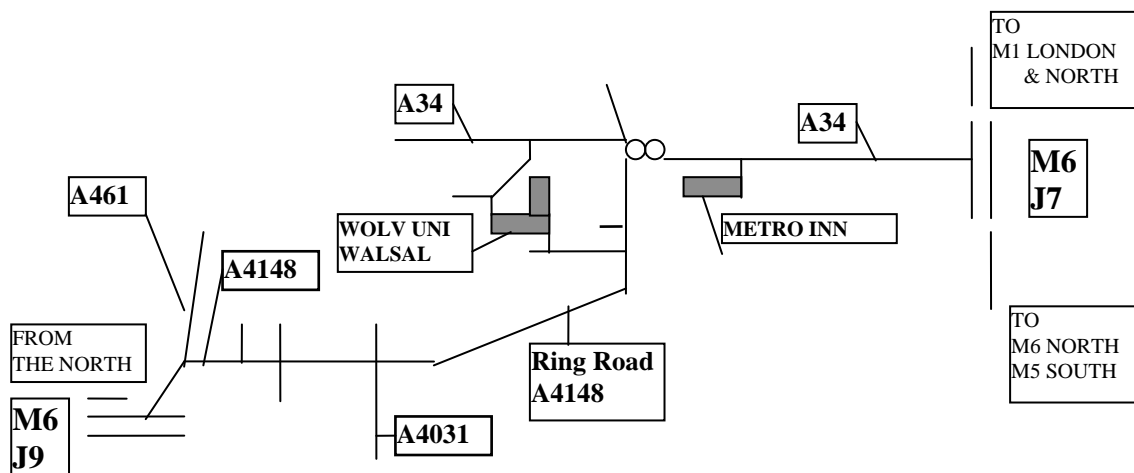

People attending the meeting must park their vehicles in CAR PARK. PLEASE DO NOT PARK ON THE GRASS.

Follow signs to RECEPTION, a porter will then direct you to the correct room.

You are advised to bring your own refreshments.

The premises has a NO-SMOKING rule.

4. Comments required from leagues on:
NASA Rules & Regulations - Clarification's, Changes for future etc.

=====

2015 NATIONAL AUTOGRASS CHAMPIONSHIPS - GENERAL SCRUTINEERING INFORMATION SHEETS.

The following is what is generally required at the NAC's.

The independent measurers for post final checking of vehicles, which should be available from 4.00pm to 12 Midnight on Sunday.

NAC:- Host League & NASA Officials.

Ladies & Junior NAC:- Host League & NASA Officials.

They will only measure and provide figures, actual engine cc is to be calculated by NASA Scrutineering Officials.

Also they will not necessarily measure the bore/stroke etc. of every vehicle, due to number of vehicles to be checked and short period of time available some measuring will be done by NASA Scrutineers, in the event of a dispute the independent measurer can check measurements taken by NASA Scrutineers. There is a temperature gauge available to obtain the temperature of the measured parts if necessary.

b). Scrutineering system.

As outlined in the NAC File with must be adhered to. Formal pre-checking of vehicles introduced.

For the Men's NAC:- 10 lanes are required, one per class - each lane to be 10 ft wide.

For the Ladies & Jnr NAC:- - Each scrutineering lane to be 10 ft wide and depending on the number of vehicles entered some classes may share lanes i.e. 2 Class 1 lanes, Class 2, Class 3 & 7, Class 4,5, & 6, Classes 8,9, & 10.

Where a vehicle is shared both drivers must be with vehicle when it is scrutineered. e.g. Class 1 Jnr. & Lady driver's. This to ensure the safety harness, crash helmet, seat, headrest etc. properly fit both driver's.

Both drivers must undergo a brake test.

Ambulance/First aid facilities to be available from start of scrutineering in case of injury/accidents in check lanes.

Scrutineering PASS stickers (pre-adhesived) for vehicles must be provided by host League, they are to be as NASA approved design and delivered to Scrutineers Secretary well in advance of start of scrutineering at each NAC.

Scrutineering cannot begin until the stickers are available for use by the scrutineers.

Host League scrutineers responsible for 1st safety check lane, under the control of Host League Chief Scrutineer.

Host League C. Scrutineer to be available at all times, with a league rep available to liaise as required throughout the meeting.

NASA scrutineers responsible for 2nd general check lanes, with National Scrutineers for lanes 1 - 5, and responsible for lanes 6 - 10, with Mr D. Hardy in overall charge.

If any Scrutineer has a query the first contact is the National Scrutineer for the class involved, if answer cannot be given/agreed Mr D. Hardy will be contacted to give final ruling.

Scrutineering System - for Friday/Saturday checks the driver will be given the form at Bay 1 – Brake and safety checks, Scrutineers sign form state if passed/failed. If passed driver will present to Bay 2 scrutineer. Scrutineers checks vehicle. Once driver have been given a “Pass” the ‘Bay 1 & 2’ form is handed to signing on person.

If the driver loses the form then the vehicle will be completely re-scrutineered.

Sunday. If the vehicle is to be re-scrutineered for any reason then a new form will filled in accordingly and the vehicle re-checked using that form.

Host League to provide a 'signing on' marshal at end of each 2nd check lanes. Also, each 'signing on' marshal to be provided (by Host League) with a suitable clipboard, pen, and container/plastic bag for scrutineering forms.

All 'Bay 1 & 2' scrutineering forms to be returned to Scrutineers Secretary after scrutineering ceases on each day.

If inclement weather forecasted then it is recommended that end of 2nd check lanes to be provided with waterproof covering. e.g. scaffolding and tarpaulin cover.

All 2nd check lanes shared i.e. not wholly manned by scrutineers from same league.

Scrutineers cannot check their qualified class, or that of their partner/child, if they or their partner/child is racing at the NAC's.

Driver to be in race trim i.e. with overalls, helmet on, vehicles to be without tools, spare wheels, jacks, etc.

VEHICLE IDENTIFICATION CLUB LETTERS & NUMBERS TO BE PLAIN BLACK ON WHITE PANEL - AS SHOWN ON DIAGRAM IN RULE BOOK.

(No shading, blocking, outlining, leaning, “Stock Car” styling, etc.).

When dealing with drivers etc. all scrutineers must try to be as tactful and as helpful as possible.

If a driver is abusive, scrutineers can refuse to check his/her vehicle and the driver will be reported for disciplinary action by NASA.

Vehicles in doubt to be directed to one side, to prevent build up of queues etc.

Marshals (minimum 10 No.) required from Host League to keep out Mechanics, Drivers family, friends, children and all other spectators etc.

RESERVE vehicles may be scrutineered on the Friday evening.

Reserve vehicles will be scrutineered, then directed to a separate holding area until they are informed whether they are required, Drivers are advised to stay with their vehicles.

Substitute vehicles must have the correct form with them otherwise they cannot be scrutineered. **SUBSTITUTE vehicles may be scrutineered on the Friday .**

Substitute vehicles will be directed to the pits.

Refreshments must be available to scrutineers from start of scrutineering, on Friday eve up to and including the end of Post Race scrutineering on Sunday evening.

Scrutineers will be given passes etc. Host League C. Scrutineers to check arrangements for refunds etc. to Officials at each NAC. NAC treasurers to liaise with Scrutineers Secretary regarding numbers of scrutineers eligible for refund.

N.B. : All Scrutineers must pay the race meeting entry charges, unless they are given complementary tickets. Men's NAC: Scrutineers who "work" on Friday afternoon/eve only and disappear for rest of NAC's will not be eligible for refund.

Separate camping will be provided for Officials including scrutineers, to allow minimum disturbance to other campers etc.

Camping site open : NAC: **Thursday** to **Thursday**
Ladies/Jnr NAC: **Thursday** to **Monday**

Host Leagues to confirm Officials camping areas & dates/times to all NASA Leagues etc.

The pits/vehicle storage areas:

These will be patrolled during the nights. For vehicles not racing at the Men's NAC's but racing locally after Men's NAC's a separate compound may be made available for storage, such vehicles will not be permitted to be stored in campsite. ---- Host League C. Scrutineer/L. Chairman to confirm & advise.

Scrutineers & Officials own vehicles to be given priority at scrutineering, as this will release them for scrutineering & official duties as soon as possible, otherwise unnecessary delays may occur.

Scrutineers vehicles will be checked by the NASA Chief Scrutineer and National Scrutineers.

All vehicles will have raced and therefore should be legal. Vehicles with major faults should not have qualified.

Scrutineers to check qualified vehicles before the NAC's & ensure that defects were fixed.

Should any vehicle fail completely to pass Pre - Race scrutineering all defects must be listed in both the Licence and Rule Book of the driver, this will prevent such vehicles racing until faults corrected.

The welding bay costs must be on display, e.g. cost per foot of metal, etc. and will be reasonable.

Class 2 restrictors will be paint sealed at pre-race scrutineering.

Post Race Scrutineering:

Ambulance/First aid facilities to be available in case of injury/accidents in scrutineering area.

Marshals to be provided by host league to keep spectators etc. out of scrutineering areas.

Those attending including competitors, mechanics, must sign the attendance sheet for identification purposes.

Badges will be provided for post race scrutineering, in order to identify those people that are entitled to be there, all others will be told to leave the checking area.

Marquee will be provided for scrutineers, with tables & chairs and plywood floor etc.

Following to be provided:-

Engine hoist - 2 No to be provided by host league.
Sturdy Benches for engines.
Lighting for evening use.
Containers/boxes required for waste oil, parts etc.
Rags etc. to be provided.

A few tools to be provided by host league.

All must be marked as property of host league to prevent them going "missing". Some items have disappeared at previous NAC's. i.e.

- | | | |
|--------------------------|------------------------------------|-------------------------|
| a) Mini flywheel puller. | b) 2 No. Valve spring compressors. | c) Spark plug spanners. |
| d) Hammer. | e) Set Screwdrivers | f) Set Metric spanners. |
| g) Set AF spanners. | h). 32mm socket for Mini. | |

Scrutineers to keep vehicles under observation; - to prevent drivers altering/removing illegal items. etc.

Independent measurer - provided by Host league. - see earlier discussion.

Strip downs - Depending on time available, type of engines and weather conditions etc.

All finalists in Class 1.

All finalists in Class 2 will have their restrictors checked and bore/stroke & Palgrave checks as required.

If conditions and time etc caused the all Class 2 Finalists to be not checked the remainder will be sealed.

First and second in class 3, 4, 5, 8 & 9 will have bore/stroke check and or be sealed.

Second in the above classes is checked as a precaution in case the first place vehicle is found not to comply with the cc rules.

First in Class 6, 7, &10. - Depending on types of engines.

The principal Class Scrutineers must be with the respective class vehicles during post race scrutineering.

N.B. Vehicle driver & mechanic to provide own tools(including any specialist tools required) and remove items as directed by scrutineers.

Vehicles must be checked prior to removal from race meeting, otherwise any prizes etc. will be forfeited.

Abuse from Driver/mechanic, families, club/league officials will be noted and passed on to NASA Directors for disciplinary action.

If a driver/mechanic persists in being abusive the Scrutineering Officials can refuse to proceed with the check, and the vehicle will be deemed illegal, and all prizes forfeit.

There may be NASA Directors in the area to observe, in order that they glean a clear picture of events to assist them in making decisions should any vehicle be reported to them for irregularities, and if there are any appeals.

Should any vehicle fail Post - Race scrutineering all defects must also be listed in both the Licence and Rule Book of the driver, this will prevent such vehicles racing until faults corrected (see also reference to form VL1).

All scrutineers etc; to emphasise the above to qualified drivers in own leagues.

The same system of post race scrutineering forms would be used as in previous years.
This involved the issue of various forms to the drivers of vehicles attending post race scrutineering.

Form D1:

Will be issued to drivers of vehicles found not to comply with rules, listing faults and stating that vehicle cannot be raced again until it complies with rules.

Racing under appeal".

At NASA events there is no such thing as 'Racing under appeal', if a vehicle has been reported for failing post race scrutineering then it **CANNOT** race at **ANY** race meeting until the defects have been corrected, and form VL1 filled in.

Form VL1.

Will be issued with form D1, to be filled in by local League Chief Scrutineer once vehicle has been checked and found to comply with rules.
There is a tear off strip at bottom of form to be returned to Scrutineers Secretary for information.

The remaining part of the form to be retained by the driver and kept with his licence to be produced at scrutineering every time the vehicle is raced until the end of the year.

(This to prove to others that any faults found have been corrected to prevent the driver being "victimised" at race meetings following the NAC's)

Form AP1.

Is issued with form D1 and VL1 should the driver wish to appeal, to be returned to NASA Secretary within 7 days.

Copies of any of the above issued at the NAC's will be passed to NASA Secretary and Local League Chairmen etc.

Form CL1.

For legal vehicles, drivers will be given this form for claiming oil allowance and cost of gaskets.
To be returned to NASA Secretary complete with receipt for gaskets within 7 days.

N.B. The gasket costs will only be paid for vehicles stripped on the day on the field.

Up to a maximum of : Class 1 & 2 £50, Class 3 - 10 £50.

Oil allowance of: All Classes - £20.

Where a driver insists on having the engine checked at the vehicle's owners garage/engine builders premises, the driver must pay in advance the NASA approved scrutineers travelling costs, at the NASA approved rate per mile.

This check must be done within 14 days of the NAC concerned.

If the driver refuses to pay, the vehicle will be deemed as being illegal and all prizes forfeit.

The driver may subject to the NASA Directors and the NASA Chief Scrutineer's approval, be checked at the NASA approved scrutineers premises.

CLASS SCRUTINEERS:

Orange Officials Jackets:

Any jackets "borrowed" at previous years NAC's be returned at this years NAC's please. Some have been seen in use at various League Open meetings.

Leagues will be charged for them if not returned.

Scrutineers.

A letter is sent in April/May to each League Chief Scrutineer requesting names, for duties at the NAC's. The listing shown is based on returned information.

Scrutineering:

MEN'S	(All to be confirmed)	LADIES & JUNIOR	(All to be confirmed)
FRIDAY: Noise Testing	2.00 pm – 3.30 p.m.	FRIDAY: Noise Testing	2.00 pm – 3.30 p.m.
FRIDAY: Scrutineering	2.00 pm -- 4.00 p.m.	FRIDAY: Scrutineering	2.00 pm – 4.00 p.m.
	5.00 pm -- 8.00 p.m.		5.00 pm – 7.30 p.m.
SATURDAY: Noise Testing	7.30 am – 8.30 am	SATURDAY: Noise Testing	7.30 am – 8.00 am
SATURDAY: Scrutineering	7.30 am – 8.15 am	SATURDAY: Scrutineering	7.30 am – 8.30 am
SUNDAY: Noise Testing	As required	SUNDAY: Noise Testing	As required
SUNDAY: Scrutineering	8.30 am -- 9.00 am (Repaired vehicles only)	SUNDAY: Scrutineering	8.30 am -- 9.00 am (Repaired vehicles only)

Bay 1: Host League members: Host Leagues to forward list of names a.s.a.p. Minimum = 6 Scrutineers & 4 Marshals Total = 10.

Bay 2 Host League members: "Signing On" personnel - Minimum = 1 per lane Total = 10.

Bay 2 : NASA CLASS SCRUTINEERS LIST PROVISIONAL

CLASS	MEN'S		LADIES & JNR	
	SCRUTINEER	CLUB/LEAGUE	SCRUTINEER	CLUB/LEAGUE
1	C. Cook		C. Cook	
	T. Appleton		T. Appleton	
	Dave Digby		Dave Digby	
	M. Morris		M. Morris	
	F. Mcleod/D.Bryan		F. Mcleod/D.Bryan	
2	A. Taylor		A. Taylor	
	C. Taylor		C. Taylor	
	D. Robins		D. Robins	
	S. Smith		S. Smith	
3	D. George		D. George	
	I. Fay		I. Fay	
	T.Simmonds Grant		T.Simmonds Grant	
4	K Jones		K Jones	
	R. Napier		R. Napier	
	S. Turley		L. Blaber	
	L. Blaber			
5	J Knipe		J Knipe	
	K. Chapman		K. Chapman	
	P. Tateson		P. Tateson	
6	R. Corbett		R. Corbett	
	M. James		M. James	
	J. Napier		J. Napier	
7	G. Bennetto		G. Bennetto	
	J. Heselton		J. Heselton	
	K. Smith		K. Smith	
8	P. Cooper		J.Sp	
	S. Rawsthorne		K. Taylor	
	K. Taylor		J. Rawlinson	
9	N. Rawlinson		<i>A.N. Other</i>	
	J. Rawlinson		<i>A.N. Other</i>	
	R. Simmonds		8,9,10.	
10	M. Adams		M. Adams	
	A. Hornshaw		A. Adams	
	A. Adams		N. Rawlinson	
			<i>A.N. Other</i>	

TYRES – T. Allen

NOISE: G. Makar
R. Hazzard

G.Makar
R. Hazzard

Other Scrutineers are required to replace 'A.N. Other' and welcome to turn up on day & volunteer.

Note.

Each Scrutineer will be given refund & award to commemorate work at NAC's.

Scrutineers to remain within allocated lanes. They must not congregate around vehicles in neighbouring lanes. This may give a mistaken impression that the vehicles concerned are illegal when they may be not.

ROLL CAGES :- Random checks to be done in Bay 2.

ROLL CAGE checks to be random as it is not practical to check every bar on every roll cage. Also local scrutineers should have already checked them.

The list is provisional, there will be a meeting of scrutineers at approx. 1.45 p.m. on Friday eve to confirm class allocation, as not all scrutineers listed may be available.

If any other scrutineers not mentioned wish to help at the NAC's then would they please contact Scrutineers Secretary as soon as possible.

Class 2:

All restrictors will be paint sealed in Bay 2. The seals cannot be broken without the presence of a Class 2 Scrutineer. If a seal is found to be broken without authorisation then the vehicle will immediately be disqualified from the NAC.

Duty Scrutineers:

There will be two scrutineers on duty at all time during the NAC's, to re-scrutineer vehicles following accidents, roll over's etc. They will be picked for a 2 hourly shift basis on each day.

De brief Meeting:

After each scrutineering session there will be a short meeting of scrutineers to discuss problems etc. at the NAC's.

Start-line:

As each Class is in the in the starting bay area, there will be the Class scrutineers available to ensure that helmets, and safety harnesses are a good fit on the driver, and to check that the vehicles have not been subject to an illegal modification to gain advantage etc. e.g. removal of silencers. Scrutineers whose Class is not in the areas must not congregate in the Start-line areas.

Repairs to vehicles cannot be done in Start-line area.

Host League to ensure that there are enough Start-line personnel to line up vehicles etc. in the past scrutineers have often ended up doing it.

Re-run lane: Repairs to vehicles:

The Chief Marshal agrees repairs will only be done in the re-run lane, within his specified time limit. Only Driver and 1 Mechanic allowed. If the vehicle is not ready then the re-run will continue without affected vehicle. Also any vehicle needing major repairs as a result of taking part in a race must be re-scrutineered following repair and before being permitted to enter re-run or any other race.

NOISE: - Noise tests will be carried out.

Person responsible for noise testing is to be confirmed. A team of approx. 3 helpers is required for the NAC's.

There will also be random noise tests upon vehicles during the race meeting.

There will be no tolerance on the NASA set noise level of 102 dBA.

It was pointed out that at previous NAC's certain drivers had altered their exhausts after passing the noise test but prior to a race to remove or amend modifications necessary to pass the noise tests.

ANY DRIVER DOING THIS WILL BE IMMEDIATELY DISQUALIFIED FROM THE RACE HEAT or FINAL CONCERNED.

Also the chief marshal may request a noise check for certain vehicles as they leave the race track to enter the pits. If they are found to be above the noise limit they will be disqualified from that race.

To ensure that there are no failures due to excessive noise it is recommended that vehicles are tested at local level, any vehicles found to be on the limit are encouraged to increase the amount silencing fitted.

NOISE:

- i. Recommended that all start line scrutineers/personnel wear ear defenders/ear plugs as the noise levels can be above a limit of 90 dBA/per hour, which if a person is continually exposed to may cause permanent hearing damage.
- ii. Classes 7, 8 and 10 particularly motorbike engined vehicles have been found to be close to or above the limits, the original bike engine silencer is not always sufficient to ensure compliance with noise limit. This to be drawn to the attention of the vehicles driver's.

HEADRESTRAINTS:

- i. Particular attention will be paid to head restraints for all vehicles, please ensure compliance to rules for all vehicles, including those fitted with high back competition type seats. The head restraint of such seats is not always high enough and an additional head restraint may need to be fitted, this is easier to do at home, rather than in a panic at the NAC's.

NOTE. The practise of allowing temporary modifications to enable head restraints to comply is no longer acceptable and will not be permitted.