

# NATIONAL AUTOGRASS SPORT ASSOCIATION LTD



SCRUTINEERS COMMITTEE MEETING

REF: S3MIN0617/VM/GIJ

SUNDAY, 10th JUNE 2017 - 11.00 am

METRO INN, Birmingham Road, Walsall WS5 3AB.

Present

<b>C. SCRUTINEERS</b>	<b>No.</b>	<b>LEAGUE</b>	<b>SCRUTINEERS CLUB</b>
Y	16	CGTRO(LINCOLN)	EA
Y	14	EAST ANGLIA	EM
Y	01	EAST MIDLANDS	Eve
Y	11	ESSEX	Rad
*	24	FENLAND	Southern
*	02	GLOUCESTER	SN
Y	23	IRELAND	SH+TD
*	18	KENT	TD
Y	07	MIDLAND AP	
Y	09	NORTH WESTERN	
*	21	NORTHERN IRELAND	
Y	10	NORTH YORKSHIRE	
*	25	SCOTTISH	
Y	15	SHROPSHIRE AA	
Y	05	SOUTHERN	
Y	04	SOUTH WALES	
Y	19	THE DALES	
*	06	WEST MIDLANDS	
Y	22	WILTSHIRE	
*	12	YORKSHIRE	

NASA Assistant Scrutineer.  
NASA Assistant Scrutineer.  
NASA Scrutineers Secretary.

APOLOGIES: NASA Director – Scrutineering.

Scrutineers marked + are Club scrutineers representing League in place of League Chief Scrutineer.

VISITORS:

**ASSOCIATION OF  
AUTHORISING  
BODIES**

Office: 46 Brookside, Alconbury, Huntingdonshire PE28 4EP  
Registered in England and Wales – Company No. 1716574

## 1. INTRODUCTION.

NASA Scrutineer RS welcomed those present, and thanked them for attending. He then handed chair to NASA Scrutineers Secretary.

## 2. MINUTES OF PREVIOUS MEETING - 14/04/18 and MATTERS ARISING:

Page 1. Class 1 - Vehicle Ride Heights.

Mr NT (Eve) commented that he had checked many of the attendee's vehicles at last weeks MAP open. There were issues with approx 15 vehicles. Some he knew were in virtually standard trim with no suspension spring alterations from standard. The current rules regarding ride height were becoming problematic to police. He suggested that more attention should be given to the vehicle camber and castor settings instead.

Brief discussion followed including reference to. Standard and replacement standard springs tended to "settle" after a few race meetings as they are softer than any uprated units. Several competitors replace springs on a regular basis @ approx £60 a time. The ride height rules must be enforceable. Is the rule needed? Lowering from standard may work on "road" but not necessarily on our dirt tracks. Lowering alters suspension & driveshaft angles often without actual benefit.

NASA Scrutineers Sec. commented that the above would be taken into consideration during discussions regarding the 2019 edition rules.

There were no other matters arising.

PROPOSED: EA

SECONDED: CGTRO

That the minutes be accepted as a true record.

**UNANIMOUS**

**CARRIED**

## 3. CORRESPONDENCE:

### CGTRO

1. Harness mounting eye bolts for Micra's.

The CGTRO rep. showed a sample of a home made eye-bolt. A standard hexagon head bolt with cut off eye bolt welded to top.

NASA Scrutineers Sec. invited comments.

Brief discussion followed including reference to. Home made types not acceptable due to varying standard of production and likely failure.

It was agreed that:

Proprietary eye bolts only are permitted.

Drilling and re-tapping of standard bodyshell harness fixing is permitted.

For "Clip on" harness 10mm (3/8") eye bolt required.

For "Bolt in" harness fixing 10mm (3/8") bolt required.

"Bolt in" harness to a steel seat frame/cradle off "floor frame" permitted.

2. Safe recovery of Class 7 vehicles.

The CGTRO rep. commented that this was a request from the league recovery crew.

Précis' of letter.

Most class 7 vehicles may not be lifted with fork lift or teleporter without a counter balance weight (Person sat on front!!).

Recovery crew suggesting fitting of lifting eye to main hoop with safety chain to minimise rotation.

NASA Scrutineers Sec. invited comments.

Brief discussion followed including reference to. Bonnet sitting not permitted. Use of extended long forks and ratchet strap with recovery from rear or front of vehicle rather than side, seem to work for most other leagues/clubs.

It was agreed that it is up to each league/club to work with own recovery crew to agree method of recovery due to the varied vehicles raced.

Class 4 – emailed suggestions.

NASA Scrutineers Sec. commented that many had been received in response to NASA Director VM request for feedback.

S. Forsey, S. Bennet, M. Kiely. P. Boland. Atspeed Racing. A. Henley Y777. H. Jones CM7. G. Evans. A. Scourfield.

A. Theakston WR67 Wesley Johnson IK34. R. Martin IK4. V. Appleton. T. Appleton.

Class 4 will be discussed later in meeting.

There was no other correspondence received.

#### **4. VEHICLE CONSTRUCTION RULES & REGULATIONS.**

##### **a. Class 1 & 2. Experimental vehicles / Trials.**

NASA Scrutineer RS commented that the situation was mainly as at previous meeting.

Class 1. - He was still awaiting details of vehicle.

Class 2.

Mr Hinton's Yaris is racing and is competitive. The vehicle has a modified exhaust and suspension coil over's. –as previously agreed by others when vehicle first built.

Mr Owens' Yaris is racing and also competitive. The vehicle has standard exhaust and suspension.

There is another Micra being built as a Class 1 specification but fitted with 1300 engine. It is due to be raced soon.

The EM rep. enquired if any decision had been made yet regarding these vehicles future use.

NASA Scrutineer RS commented that the monitoring will continue for now and a decision made probably at end of racing season.

##### **b. Tyres – Update /**

NASA Scrutineers Sec. commented that NASA Director VM was still in correspondence, now at a higher level, within Maxsport. Some progress had been gained since previous meeting.

The MAP rep. explained that monitoring of tyre hardness had taken place at the recent MAP Open.

Before Race – Maxsport units - @ 34 degrees = 44 @ 39 degrees = 54  
Others - " = 46 " = 48

The tyre date stamps had not been checked.

It was agreed to continue monitoring.

##### **c. Scrutineering Report.**

###### General.

Report not received.

###### Licence – Missing Photographs & Unsigned – Reminder.

NASA Scrutineers Sec. explained that each competitors licence must be complete with a recent photograph and be duly signed with the competitor's normal signature. This is a mandatory requirement to ensure correct identification of the competitor concerned and prevent impersonation.

No "infant" or "old school" nor "childish" nor "old" photographs. The photograph must be reasonably "up to date".

No correct photo or no signature or both missing then no race.

The Licence is not valid without either therefore the person concerned is not permitted to race.

Brief discussion including reference to photo may be required to be sent in with licence application in future for validation stamp or similar etc. However this will be a Board discussion and decision.

*NB. The roll cage blue tag number must be listed.*

*The emergency contact & medical alert details should also be completed.*

###### Licence - Listing of Faults in Licence – Reminder.

NASA Scrutineers Sec. explained that each competitors licence must include reference to any vehicle faults. This so that when the competitor next presents vehicle for scrutineering it may be assessed to ensure faults have been rectified.

###### Class 4 – Feedback/Future Regs.

NASA Scrutineers Sec. commented that the various suggestions received via email were mixed. Some achievable. However the most popular were.

1. Allow a cylinder head change for 2 valve engines.

2. Increase class limit cc. to 1200/1300 for 2 valve engines.

– (This would however have a knock on effect to Class 5 cc limits).

3. 16v engines – leave as at present.

The matter is not closed therefore further suggestion are still welcome.

NASA Scrutineers Sec. invited comments.

The CGTRO rep. commented that the class was dying. Leave everything as at present and delete class after 5 years.

The EM rep. commented allow 1600cc and under stock hatch vehicles into Class 4. Some have raced locally and are competitive with existing Class 4 vehicles. Also less costly to build and race.

Brief discussion followed including reference to. Any changes must be affordable. The change of cylinder head means more expense for those who wish to change heads. Increase in cc may mean that current 1000cc and 1128cc (1118cc+ based on 1071 S) mini engines may be scrap as the cranks & rods and some blocks needed will be different and originals redundant. By changing rules it is likely making class even more expensive for mini users. Increase in cc may have effect on few remaining Class 5 FWD.

NASA Scrutineers Sec. confirmed that all of the received emails, and meeting comments will taken into consideration during discussions regarding any amendments to the Class 4 engine cc and modification requirements for 2019 edition rules.

Also any such rule book proposed changes to class 4 would have to be ratified by NASA Board before being implemented. There would also be a period of notice.

Saloons - Seat Mountings – Reminder.

NASA Scrutineers Sec. confirmed that the seat must not be mounted direct onto any body panel – standard floorpan and or floor frame floorpan. Vehicle panel mounted seats can be affected by panel deformation during an on track incident.

The seat must be mounted onto a steel cradle/frame.

Class 4 & 6 - Rear protection & Bodywork – Lack of – Reminder

NASA Scrutineer RS commented that there is concern regarding the lack of rear protection on some vehicles.

Rear protection is permitted but not mandatory – Should it be made so?

Brief discussion followed including reference to some competitors not fitting protection bars to save weight. Such weight savings are negligible. Protection bars help support rear bodywork. Also act as secondary safety in event of rear impact. Should it be compulsory? Past instance of competitor hospitalised with broken neck and other injuries due to severe crushing of rear bodywork and cage movement in heavy rear impact.

It was confirmed that where there are concerns regarding a very flimsy rear bodyshell, then scrutineers may require protection bars to be fitted.

NASA Scrutineers Sec. confirmed that meeting comments will take into consideration during discussions regarding any amendments to the Class 4 & 6 protection requirements for 2019 edition rules.

Junior Specials – Rear Suspension - Top Mounting & Spring Cups – Reminder.

NASA Scrutineer AT commented that the rules require the original top spring seal, cup and rubber be retained.

(See Photo Below).

It has been found on several vehicles that these have been removed and replaced with a spring adaptor or similar, particularly when a 2.5" coil spring has been fitted in place of the original larger standard diameter spring.

The discarding of the top spring seal, cup and rubber makes the vehicle concerned non-compliant to rules.



The tie bar

This must be secure. Where say 2 bolts instead of 3 are used then provided the tie bar is secured it is permitted to use 2 bolts.

Rear track control bar

Sliding mounting rear track control bars permitted.

Junior Specials – Front Suspension

Sliding mounting shock absorber units permitted.

For info.

Specials Seat Mounting. NB. Must be chassis mounted. Not floor/side panels.

Specials Foot Pedal Mounting. NB. Must be chassis mounted. Not floor panel.

**d. National Autograss Championships 2018**

Pre Nationals Scrutineering of Vehicles.

Fast Track/Path: If vehicles are pre scrutineered and drivers have correct forms then the vehicle concerned is eligible for “fast track/path” checking provided the league concerned has been represented at this meeting today.

NASA Scrutineer AT commented that vehicles that Fast Track/Path compliant vehicles may be considered for fitting of a “Red tag”.

NASA Scrutineers Sec. issued all with copy of “Fast Track/path” (Pre-season checklist) to be used to pre-Nationals scrutineering of qualified vehicles.

NASA Scrutineers Sec. commented that there is a Class 7 vehicle in car park. For any that require tuition in use of form then this would take place after meeting. All here are experienced scrutineers and attendance is not compulsory.

i. Club & League responsibilities. - Club and League all in hand.

Bay 1 - Host league to supply 6 persons for brake/safety checks.

Bay 2 – Host league to supply sufficient “Signing on” persons.

Signing on will no longer take place at end of scrutineering lanes.

Separate signing on point to be provided – Scrutineering Tent?

ii. General.

Any illegality to be refused.

Note. Only very minor repairs for compliance will be permitted.

Race cars found with non-compliant components at pre-race checking e.g. Class 1 - Modified rear trumpets, alloy pedals, alloy roll cage feet plates etc; will not be permitted to race. The non permitting of such parts is well known therefore their use will be deemed as deliberate non-compliance and hence immediate disqualification.

Pre- NAC checking at local league/club is highly recommended.

3 No. Scrutineers per class on lanes plus someone doing paperwork.

Lanes:

Class 1.

Class 1 & 2 – Fast Track.

Class 2.

Class 3.

Class 4 & 6.

Class 5 & 7.

Class 8, 9 & 10.

Class 8, 9 & 10.

Class 3 - 10 – Fast Track.

E.G.

	Class 1	Class 1 & 2 Fast Track	Class 2	Class 3	Class 4 & 6	Class 5 & 7	Class 8, 9, 10.	Class 8, 9, 10	Class 3, 4, 5, 6, 7, 8, 9, 10. Fast Track	
--	---------	---------------------------	---------	---------	-------------	-------------	-----------------	----------------	--	--

Marshalls from host league required at head of lanes to direct vehicles to correct lanes.

If pre-scrutineered vehicles competitors do not have pre-check forms with them, then they will not be permitted to "Fast Track" and must be fully scrutineered in their appropriate lane.

Noise Test. To be confirmed.

Scrutineers.

A letter is sent in April/May to each League Chief Scrutineer requesting names, for duties at the NAC's.

A few Leagues have already replied - Any more??

*Note. Volunteer scrutineers will be given pass and award for "Working" at NAC's.*

*NASA Director VM to liaise regarding pre-paid passes.*

NASA Scrutineers Sec. commented that the response this year was disappointing. Few had returned the forms. Therefore any outstanding forms and or volunteer names must be returned to him asap. Leagues may send by post or email.

More persons are required.

See Scrutineering times guide in reminders section at end of minutes.

**Bay 2 : NASA CLASS SCRUTINEERS LIST PROVISIONAL**

CLASS	MEN'S		LADIES & JNR	
	SCRUTINEER	CLUB/LEAGUE	SCRUTINEER	CLUB/LEAGUE
<b>1</b>  Diagnostics Diagnostics	<b>N. Taylor</b> <b>R. Taylor</b> <b>Dave Digby</b> <b>F. McLeod</b> <b>Josh</b> <b>M. Brown</b> <b>P. Peek</b>	SN EM	<b>N. Taylor</b> <b>R. Taylor</b> <b>Dave Digby</b> <b>F. McLeod</b> <b>Josh</b> <b>M. Brown</b> <b>P. Peek</b>	SN EM
<b>2</b>	<b>N. Taylor</b> <b>C. Taylor</b> <b>A. Murray</b> <b>S. Smith</b> <b>R. Lillington</b>	Eve  WML S	<b>N. Taylor</b> <b>C. Taylor</b> <b>A. Murray</b> <b>S. Smith</b> <b>R. Lillington</b>	Eve  WML S
<b>Fast Track</b> <b>1 &amp; 2</b>	<b>S. Smith</b> <b>D. Robins</b>	WML EA	<b>S. Smith</b> <b>D. Robins</b>	WML EA
<b>3</b>	<b>D. George</b> <b>I. Fay</b> <b>T. Simmonds Grant</b> <b>S. Ford</b>	SN Wsx SN S	<b>D. George</b> A.N. Other <b>T. Simmonds Grant</b> <b>S. Ford</b>	SN
<b>4 &amp; 6</b>	<b>M Uka</b> M. Morgan <b>D. Robinson</b> A.N. Other	YS	<b>M Uka</b> M. Morgan <b>D. Robinson</b> A.N. Other	F
<b>5 &amp; 7</b>	<b>D. Broughton</b> <b>S. Murray</b> M. James <b>S. Houlihan</b>	SN  Ire	<b>K. Smith</b> <b>S. Murray</b> M. James A.N. Other	
<b>8, 9, 10.</b>	<b>E. Dudley</b> <b>A. Hornshaw</b> <b>K. Warren</b> D. Mullen	SN  Ire	J.Sp K. Taylor K. Butcher 8, 9, 10. <b>A. Hornshaw</b> <b>E. Dudley</b>	SN SN
<b>Fast Track</b> <b>3 - 10</b>	<b>R. Corbett</b> <b>P. Meli</b>		<b>R. Corbett</b> <b>P. Meli</b>	

**NOISE:** TBC  
TBC

TBC  
TBC

**TYRES – TBC.**

**Bold Type** = Confirmed as volunteering for 2018 NAC  
Normal Type ? = Volunteered in past not confirmed for 2018 NAC

NASA Director VM to deal with passes for volunteers.

Post race Checking

The gasket costs will only be paid for vehicles stripped on the day on the field.  
Up to a maximum of : Class 1 & 2 £50, Class 3 - 10 £50.  
Oil allowance of: All Classes - £20.

**e. Rules Clarification requests from League Scrutineers.**

Damage to Tags.

The EM rep. enquired as to situation where tag and or tag fixing wire have been damaged due to sandblasting of roll cage. E.g. a recent tag had broken away when checking number due to wire had been sandblasted and thus weakened. The vehicle had then been permitted to race.

NASA Scrutineers Sec. commented that if a tag is not fixed for any reason then a new tag is required. In this case the competitor must contact NASA Director VM to have a new tag fitted.

Ideally when sandblasting a tagged cage the tag and fixing wire should be wrapped & protected.

Also it must be noted that a second or third sandblasting of the roll cage, dependant upon pressure and material used, may result in the tube thickness becoming non-compliant.

Half Nuts.

The MAP rep. commented that these were still being found on roll cage feet fixings. A competitor had presented an invoice claiming half nuts were full nuts.

Brief discussion followed. Definition of half nut. Use of lock nut (nylock) for cage feet to specified?

NASA Scrutineers Sec. commented that if it looks like a half nut and is smaller than a full nut then it is a half nut regardless of any invoice or claim by competitor.

The use of a nylock nut is acceptable. This may be compulsory for future.

Seat belt eye bolt location.

The MAP rep. enquired if it is acceptable to fit an eye bolt as a roll cage foot fixing. i.e. 1 normal bolt and 1 eye bolt. The harness being clipped to eye bolt.

Following discussion it was agreed that provided a 10mm (3/8") eye bolt was used then it is acceptable.

Locking Wheel Nuts.

The MAP rep. enquired if it is acceptable to now use an Allen key/torx/multi-spline type nut as a wheel nut.

Following discussion it was agreed that provided the correct tool to remove the nut concerned is readily available then it is acceptable.

Class 1 Yaris – Sound Deadening.

The SAA rep. enquired is the sound deadening and internal sealer can be removed.

YES

However any external sealer must remain.

Class 1 – Micra - Wheels

Mr NT (Eve) enquired if an alloy wheel may be modified to fit. i.e. a Vauxhall wheel having centre cut/bored out.

NO – Only correct wheels for the vehicle concerned may be used. Modification to fit other make of wheels is prohibited.

Class 1 & 2 – Micra – Use of Polybushes.

Can the engine steady bar be fitted with a "polybush"? - NO

Can the gear linkage bush be replaced with a "polybush"? - NO

Bushes must be like for like.

Stock Hatch Sealing.

The arrangement must be made via Stock hatch Committee.

**5. DRAFT RULE CHANGES:**

NASA Scrutineer RS explained that the rule changes for 2019 were being discussed and another meeting due shortly.

- a. Rule change requests from Leagues. – None specific, however comments at scrutineers meetings will be considered.
- b. Rule change requests from Dir. Scrutineering. – General update of some rules including comments from constructors and various clarifications discussed at this committee.
- c. Rule change requests from NASA Board of Directors. – None additional to above.

**6. ANY OTHER BUSINESS:**

None.

Meeting Closed 1.00 p.m.

Scrutineers then inspected Class 7 vehicle outside.



N.B. REMINDERS:

1. **Rule Book & Licence.**

All members must be accompanied by their Rule Book and Licence at all times at a race meeting. Both the members Rule Book and Licence must be presented at “Scrutineering” and “Signing on” There must be a photograph of the member placed on the Licence.

2. **JUNIORS - Rule Book & Licence.**

All Junior Drivers must be accompanied by their Letter/Form of consent to race and Rule Book and Licence at all times at a race meeting.

The Letter/Form of Consent, Rule Book and Licence must be presented at “Scrutineering” and “Signing on”

There must be a photograph of the member placed on the Licence.

**“Orange” “Official” scrutineers jackets**

Not all “orange” “official” scrutineers jackets have been returned to Mr G. Jones (Sec.) following the National Championships. Could they please be returned as soon as possible.

**These jackets are intended for use at the National Championship Meetings only.**

They have not been generally issued to Clubs or Leagues for use locally.

If any are seen at race meetings then the Leagues concerned may be charged a certain sum of money and the jackets confiscated.

**2018 National Autograss Championships**

Castle Lloyd Farm  
Nr Red Roses,  
Carmarthenshire.  
SA33 4PT

3<sup>rd</sup>, 4<sup>th</sup> & 5<sup>th</sup> August 2018.

Host:  
South Wales League

[www.national-autograss.co.uk](http://www.national-autograss.co.uk)

Scrutineering times:  
(All to be confirmed)

FRIDAY: Noise Testing

2.00 p.m. -- 3.30 p.m. (Break 3.30 - 4.30)

4.30 p.m. -- 7.30 pm.

FRIDAY: Scrutineering

2.00 p.m. -- 4.00 p.m. (Break 4.00 – 5.00)

5.00 p.m. -- 8.00 pm

SATURDAY: Noise Testing

7.30 a.m. -- 8.30 a.m.

SATURDAY: Scrutineering

8.00 a.m. -- 9.00 a.m.

SUNDAY: Scrutineering

8.30 a.m. -- 9.00 a.m.

(Repaired vehicles only)

Post Race Scrutineering

SUNDAY: (After Final Races)

5<sup>th</sup> August

4.30 p.m. -- 11.00 p.m.

**2018 National Autograss Championships**

Castle Lloyd Farm  
Nr Red Roses,  
Carmarthenshire.  
SA33 4PT

17<sup>th</sup>, 18<sup>th</sup> & 19<sup>th</sup> August 2018.

Host:  
South Wales League

[www.national-autograss.co.uk](http://www.national-autograss.co.uk)

Scrutineering times:  
(All to be confirmed)

FRIDAY: Noise Testing

2.00 p.m. -- 3.30 p.m. (Break 3.30 - 4.30)

4.30 p.m. -- 7.00 pm.

FRIDAY: Scrutineering

2.00 p.m. -- 4.00 p.m. (Break 4.00 – 5.00)

5.00 p.m. -- 7.30 pm

SATURDAY: Noise Testing

7.30 a.m. -- 8.00 a.m.

SATURDAY: Scrutineering

7.30 a.m. -- 8.00 a.m.

SUNDAY: Scrutineering

8.30 a.m. -- 9.00 a.m.

(Repaired vehicles only)

Post Race Scrutineering

SUNDAY: (After Final Races)

19<sup>th</sup> August

4.30 p.m. -- 11.00 p.m.

**NOTE:**

Any scrutineer who wishes to take part in scrutineering duties at the NAC's must attend at least one scrutineers committee meeting.

1. Scrutineers must give all assistance required to drivers/constructors in preparing vehicles to comply with the 2018 Edition Rule Book.
2. For future reference: **WANTED:**  
Details, photographs, etc. of reasons for vehicles to fail scrutineering, examples of incorrect or dangerous practices.
- 3 **FUTURE MEETINGS: 11.00 am**  
**Metro Inn, Birmingham Rd, Walsall WS5 3AB**

SATURDAY

13th OCTOBER

2018 Rules - Confirmation

**NASA AGM - SUNDAY 25 November 2018**

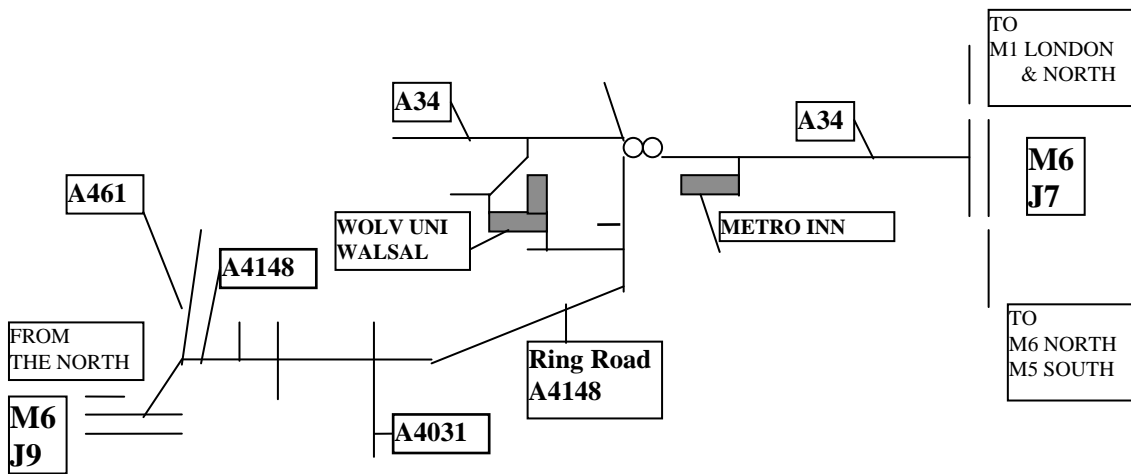

People attending the meeting must park their vehicles in CAR PARK. PLEASE DO NOT PARK ON THE GRASS.

Follow signs to RECEPTION, a porter will then direct you to the correct room.  
Enter car registration number into parking control screen otherwise there will be a charge.

**You are advised to bring your own refreshments.**

**The premises have a NO-SMOKING rule.**

4. Comments required from leagues on:  
NASA Rules & Regulations - Clarification's, Changes for future etc.

=====